

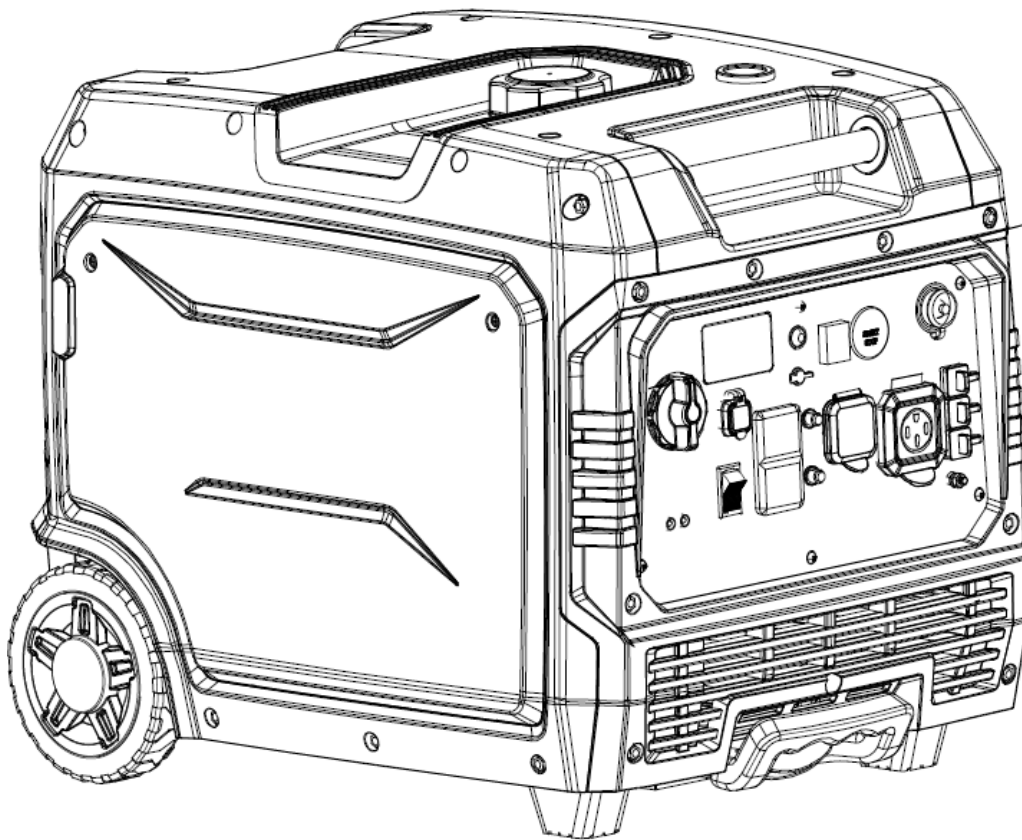

Model: PG7600BiSRCO

7600-Watt Inverter Generator

OPERATOR'S MANUAL



Caution:

- Before using your generator, please read this manual carefully to understand proper use.
- Keep this manual with the generator.



Warning: The Engine Exhaust from this product contains chemicals known to the State of California to cause cancer, birth defects or other reproductive harm.



DO NOT RETURN TO STORE!

HAVE QUESTIONS OR NEED SERVICE?



1-866-591-8921



support@pulsar-products.com

Table of Contents

Table of Contents	1	Preparation.....	5
Instruction	1	Operation.....	7
Safety Warnings and Notices	1	Maintenance	9
Safety Instructions	2	Specifications	12
Components.....	4	Troubleshooting Guide	13
Control Panel	5	Electrical Schematic.....	15

Introduction

Thank you for choosing **Pulsar Products!**

This manual provides instructions on how to safely and correctly operate your generator. Please read and fully understand this manual before using your generator. If you have any questions, contact us at **1-866.591.8921 (Monday-Friday)** or at **support@pulsar-products.com** before using your generator.

All details and images in this manual are believed to be accurate at the time of publication. Pulsar Products reserves the right to make updates to this manual at any time. For the latest updates, please contact Pulsar Support at **866.591.8921** or **support@pulsar-products.com**.

This manual is a permanent part of the generator. If the generator is resold, please include this manual with it.

Safety Warnings and Notices

WARNING: Save This Manual for Future Reference

This manual contains important information regarding the safety, operation, maintenance, and storage of this product. Before use, you must read and fully understand all cautions, warnings, instructions, and product labels. Failure to do so could result in serious personal injury and/or property damage.

Safety Definitions

 This safety alert symbol appears with most safety statements. It means to pay attention and be alert, your safety is involved! Please read and abide by the message that follows the safety alerts symbol.

DANGER

DANGER indicates an imminently hazardous situation which, if not avoided, will result in death or serious injury.

WARNING

WARNING indicates a potentially hazardous situation which, if not avoided, could result in death or serious injury.

CAUTION

CAUTION indicates a potentially hazardous situation which, if not avoided, may result in minor or moderate injury. It may also be used to alert against unsafe practices.

NOTICE

Failure to follow the instruction may result in the damage to your generator and other property.

Safety Instructions

Safety Symbols

Follow all safety information provided in this manual and on the generator.

Before operating the generator, you must read and understand this manual fully and familiarize yourself with safe operating practices.

SYMBOL	DESCRIPTION
	Safety Alert Symbol
	Electrocution Hazard
	Asphyxiation Hazard
	Burn Hazard - DO NOT touch hot surfaces
	Electrical Shock Hazard
	Fire Hazard
	Maintain Safe Distance
	Lifting Hazard
	Read Manufacturer's Instructions
	DO NOT Operate in Wet Conditions
	Grounding. Consult a qualified electrician to determine the necessary grounding requirements before operating this product.

Safety Precautions

WARNING



Operate this product **ONLY** outdoors, far away from windows, doors, and vents, to reduce the risk of carbon monoxide gas buildup, which could accumulate and be drawn into occupied spaces.

DO NOT operate this product under the influence of alcohol, while exhausted or sleep-deprived, when drowsy from medications, or under any condition that could impair your judgment or prevent safe operation.

Avoid operating this product under the following circumstances:

1. When the ground is slippery or other conditions exist, it might be difficult to maintain a steady posture.
2. It would be difficult to gain a clear view of the area at night, during heavy fog, or at any other time when one's field of vision might be limited.
3. During rainstorms, during lightning storms, at times of strong or gale-force winds, or at any other times when weather conditions might make it unsafe to use this product.

POISONOUS GAS HAZARD: Engine exhaust contains carbon monoxide, a poisonous gas that could kill you in minutes. You **CAN NOT** smell it, see it, or taste it. Even if you do not smell exhaust fumes, you could still be exposed to carbon monoxide gas.



Safety Instructions

- **Never** operate this product in enclosed or partially enclosed spaces, including homes, garages, sheds, basements, or crawlspaces, even if using fans or open windows and doors for ventilation. Carbon monoxide can build up quickly and linger for hours, even after the engine is off.
- **Install battery-operated or plug-in carbon monoxide alarms with battery backup** per the manufacturer's instructions. **Most smoke alarms do not detect carbon monoxide.**
- **Position the product downwind** and direct the exhaust away from occupied spaces. If you experience symptoms like dizziness, weakness, or nausea, immediately turn off the product, move to fresh air, and seek medical attention, as these may indicate carbon monoxide poisoning.

WARNING

Never store fuel cans or refill the fuel tank in areas with boilers, stoves, wood fires, electrical sparks, welding sparks, or any other sources of heat or fire that could ignite the fuel.

Smoking while operating the product or refilling its fuel tank is extremely dangerous. Never smoke or vape while working with your generator.

When refilling the fuel tank, always turn off the engine first. Carefully inspect the area to ensure there are no sparks or open flames nearby before refueling. If any fuel spills occur during refueling, use a dry rag to clean up the spills before restarting the engine.

After refueling, securely screw the fuel cap back onto the tank and move the product at least 3 meters (10 feet) away from the refueling area before restarting the engine.

Additionally, be aware that starter cord kickback (rapid retraction) can pull your hand and arm toward the engine faster than you can release it, potentially causing broken bones, fractures, bruises, sprains, or other serious injuries.

WARNING



Fuel and its vapors are extremely flammable and explosive which could cause burns, fire, or explosion resulting in death or serious injury and/or property damage.

When Adding or Draining Gasoline

Turn the generator engine OFF and let it cool for at least 2 minutes before removing the fuel cap. Loosen the cap slowly to relieve pressure in the tank.

- Fill or drain fuel tank outdoors.
- DO NOT overfill the tank. Allow space for fuel expansion.
- If fuel spills, wipe it up and let the area dry before starting the engine.
- Keep fuel away from sparks, open flames, heat, and other ignition sources.
- Check fuel lines, tank, cap, and fittings frequently for cracks or leaks; replace them if necessary.
- DO NOT smoke or vape anything.

Before Starting the Generator

Before starting your generator, you must read and understand the manual and familiarize yourself with safe operating practices. Improper treatment of the generator could damage it and shorten its lifespan.

Keep the handles dry, clean, and free of oil or fuel residue.

Safety Instructions

WARNING

Never touch the muffler, spark plug, or other metal parts of the inverter generator while it is running or immediately after stopping. Doing so could result in serious burns or electrical shock.

When Starting the Unit

Ensure the spark plug, muffler, fuel cap, and air cleaner are properly in place.

DO NOT crank the engine with the spark plug removed.

NOTICE

- Use the generator only for its intended applications.
- Operate the generator only on solid, level surfaces.
- **DO NOT** insert any objects through the cooling slots.
- **DO NOT** expose the generator to excessive moisture, dust, dirt, or corrosive vapors.
- If connected devices overheat, turn them off and disconnect them from the generator immediately.

Shut off the generator if:

- Electrical output is lost.
- Equipment sparks, smokes, or emits flames.
- The unit vibrates excessively.

Components

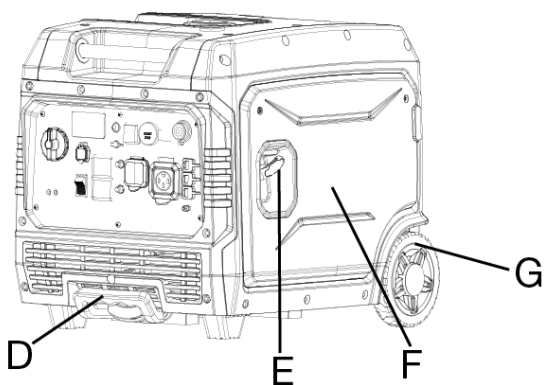
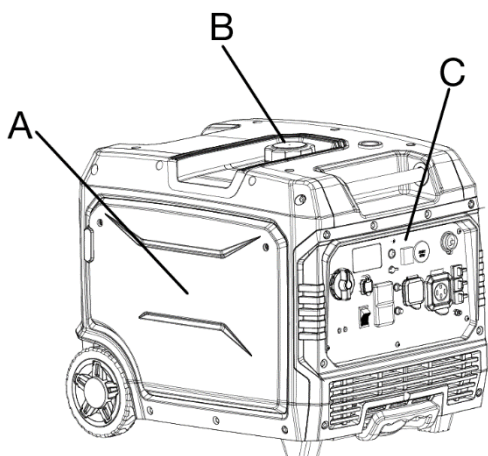

- A. **Left Side Panel:** Engine, Air Filter, Carburetor, Spark Plug.
- B. **Fuel Cap:** Use this cap to add gasoline to the generator.
- C. **Control Panel:** Contains the electrical outlets and operational controls for the generator.
- D. **Carry Handle:** Facilitates easy transport of the generator.
- E. **Recoil Handle:** Pull the recoil handle to manually start the engine.
- F. **Right Side Panel:** Add or drain oil, battery disconnect.
- G. **Transport Wheels:** Helps transport the generator.

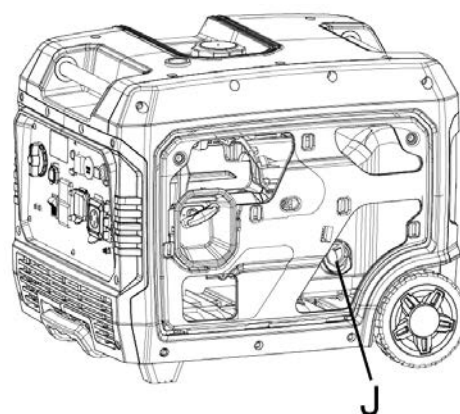
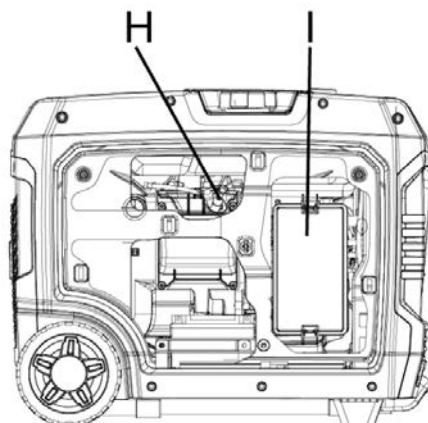

- H. **Spark Plug Cover:** This cover must be removed to maintain the spark plug.
- I. **Air Filter:** Clean or replace the air filter.
- J. **Oil Dipstick:** Unscrew the oil dipstick to check oil levels.

Control Panel

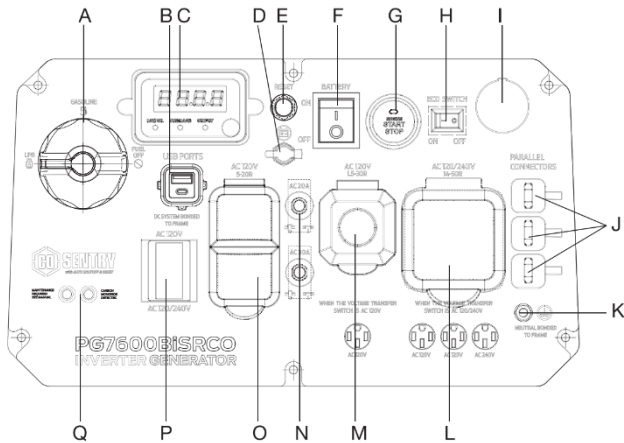

- A. **Fuel Selector Switch:** To select Gasoline or Propane.
- B. **USB Ports:** Features include USB Type A and USB Type C (5V/3.6A, 9V/2.5A, 12V/2A) ports for convenient device charging.
- C. **Digital Hour Meter:** Real-time LED display with runtime, remaining fuel, load/output, volts, and lifetime hours data.
 - ① **Low Oil Level Light:** When the oil level in the crankcase falls below the safe operating limit, the low oil level indicator lights up red and the engine will automatically shut down.
 - ② **Overload Light:** When the red light is on, it indicates that the generator is overloaded and the generator will stop output.
 - ③ **Output Light:** When the generator is running normally, the light will be green and steady on.
- D. **Battery Charging Port:** Used to charge the battery with the included battery charger.
- E. **Reset Button:** Press the reset button to start the device reset process.
- F. **Battery Switch:** Turns the battery ON and OFF. Must be ON before an electric start or remote start.

- G. **Push Button Start/Stop:** Press this button up to enable the engine start and press down to stop the engine.
- H. **Eco Mode:** Eco mode minimizes fuel consumption and noise by adjusting the engine RPM to the minimum required for the current load.
- I. **Propane Inlet:** Connect the propane hose (included) to this inlet.
- J. **Parallel Connectors:** A compatible Pulsar Inverter Generator can be connected for additional power output.
- K. **Ground Terminal:** Used to externally ground the generator, enhancing safety during operation.
- L. **14-50R Receptacle:** 120/240 Volt, AC 50 Amp, This receptacle is rated for a maximum of 50 amps.
- M. **L5-30R Receptacle:** 120 Volt, AC 30 Amp, This receptacle can supply a maximum of 30 Amps.
- N. **Circuit Breaker:** AC circuit breakers control the output of all AC sockets to protect against overload or a short circuit of the generator.
- O. **5-20R Receptacle:** 120 Volt, AC 20 Amp, This receptacle is rated for a maximum of 20 amps.
- P. **Voltage Switch:** Switch between 120V and 240V voltage as required.
- Q. **CO Sentry Indicator Lights:** The CO Sentry monitors the accumulation of poisonous carbon monoxide gas. If increasing levels of CO gas are detected, the CO Sentry automatically shuts down the engine.

Assembly

Preparation

Your generator requires some assembly. This generator ships from our factory without oil; it must be properly filled with oil before operation.

Unpacking

1. Set the shipping carton on a solid, flat surface.
2. Remove everything from the carton except the generator. It is suggested to cut one panel of the carton to facilitate assembly (a minimum of two people are required).
3. Using the carrying handles of the unit, carefully remove the generator from the box.

Packing List

Check all accessories to the following list. Contact your dealer if any parts are missing.

Included Accessories

- 1×Remote FOB
- 1×Engine Oil
- 1×Battery Charger
- 1×Warranty Card
- 1×Operator's Manual
- 1×Spark Plug Wrench
- 1×Combination Wrench
- 1×Funnel
- 1×Propane Regulator Hose

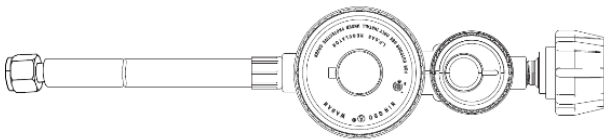

Preparation

Add Engine Oil

NOTICE

Failure to follow this instruction may result in damage to your generator and other property.

If you are operating the generator in extreme temperatures, refer to the following chart for the recommended oil type.

Recommended Engine Oil Type	
10W-30	→
5W-30	←
10W-40	→
5W-30 Synthetic	→
°F	-20 0 20 40 60 80 100 120
°C	-28.9 -17.8 -6.7 4.4 15.6 26.7 37.8 48.9
Ambient temperature	

The generator is shipped without engine oil. Do not start the engine without ensuring it has sufficient oil.

- Place the generator on a level surface.
- Remove the screws (①), then remove the cover (②).
- Remove the oil filler cap/dipstick (③).

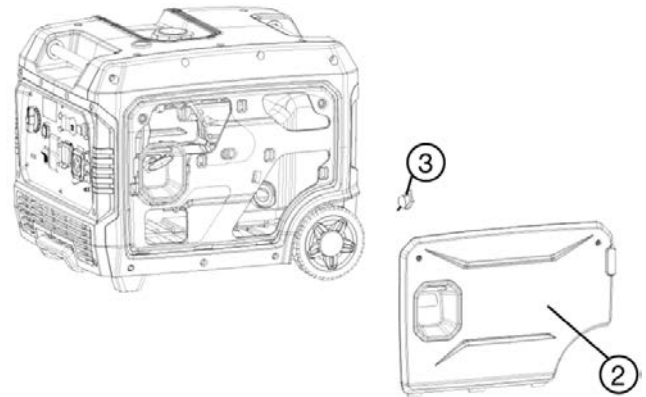
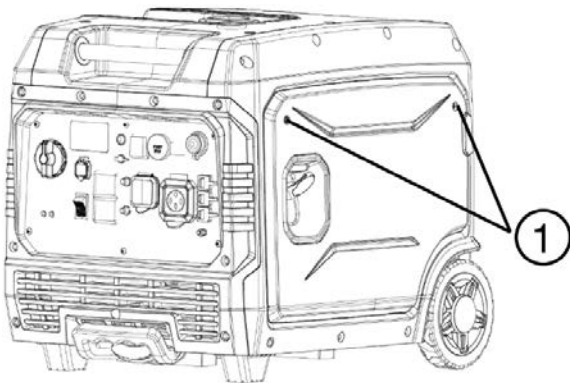

- Fill the generator with the specified amount of the recommended engine oil, then reinstall and tighten the oil fill cap/dipstick (③).
- Reattach the cover and tighten the screws.
- Important:** Do not start the engine until it has been filled with the correct type and volume of oil.

NOTICE

Recommended Engine Oil:

- Type: SAE 10W-30
- Oil Grade: API Service SE type or higher
- Engine Oil Capacity: 0.65 L (22 fl. oz)

Residual oil from the factory may remain in the engine. Add oil slowly to prevent overfilling. Once oil has been added, the oil level should be 1-2 threads below the fill hole. DO NOT screw in the dipstick when checking the oil level.

During the first 5 hours of operation (the break-in period), check the oil level frequently and operate at or below 50% of the running watt rating. Vary the load occasionally to help the stator windings heat and cool, and help seat the piston rings. After this period, change the oil.

The engine features a low oil shut-off that stops operation when the oil level is critically low. Refer to the Maintenance section for service intervals.

Preparation

⚠ CAUTION

- New propane tanks must be purged of air and moisture before filling. Used propane tanks that have not been plugged or kept closed must also be purged. The purging process should be done by a propane tank supplier (propane tanks from an exchange supplier should have been purged and filled properly).
- ALWAYS position the propane tank so the connection between the valve and the gas inlet will not cause sharp bends or kinks in the hose.

⚠ WARNING

Explosion hazard. DO NOT start the generator if you smell propane. ALWAYS fully close the LPG tank valve and disconnect the propane hose from the generator when not in use. Never invert (turn upside down) an LPG tank while in use.

Fuel the Unit - LPG

Connecting a Propane Tank

1. Turn the generator OFF and leave it on a flat surface in a well-ventilated area.
2. Verify that the propane tank valve is in the fully closed position.

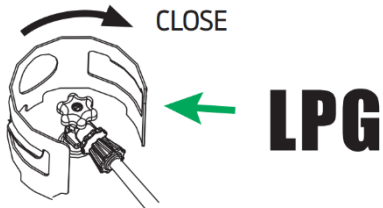

IMPORTANT: DO NOT use thread seal tape or any other sealant to seal the propane hose connection.

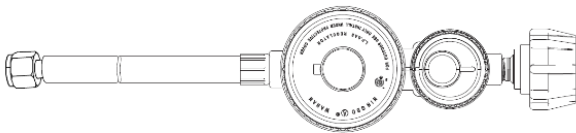

3. Remove the cap from the generator propane inlet.
4. Install the propane hose securely on the gas inlet (threaded tight) and check for a secure connection.
5. Remove the safety plug or cap from the propane tank valve and attach the regulator end of the hose to the LPG connector on the tank, hand-tighten. Then turn the fuel selector knob to "LPG".
6. Turn the propane tank valve to the fully open position. Check all connections for leaks by wetting the fittings with a solution of soap and water. Bubbles that appear or bubbles that grow indicate that a leak exists. If a leak exists at a fitting, turn the propane tank valve to the fully closed position and tighten the fitting. Open the propane tank valve and recheck the fitting with the soap and water solution. If the leak continues or if the leak is not at a fitting, then DO NOT use the generator and contact an authorized Pulsar service center.

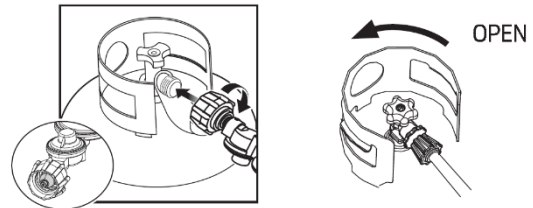

IMPORTANT: The generator battery is shipped disconnected for safety. You must connect the battery quick-connect cables before using the generator.

Connecting the battery

1. A quick connect battery plug is pre-installed on the battery and the generator, connect both as shown.
2. Never attempt to connect different colored battery wires!

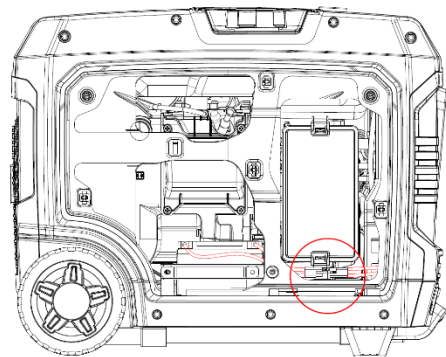

Preparation

Fuel the Unit - Gasoline

- Ensure the generator is on a solid, flat, level surface.
- Unscrew the fuel cap and set it aside.
- Slowly add gasoline to the fuel tank, taking care not to overfill. The fuel gauge on the top indicates the gasoline level.
- Replace the fuel cap and wipe up any spilled gasoline with a dry cloth, then safely remove the cloth from the area.

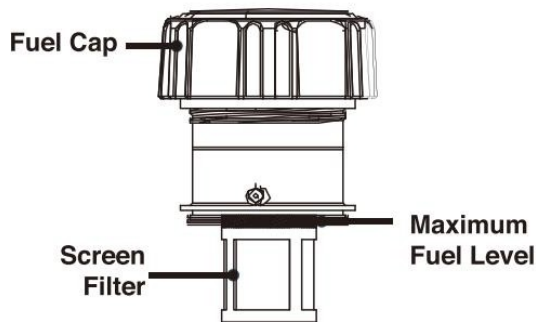

CAUTION

Remove the fuel cap and place it in a clean location. Fill the fuel tank to no more than 80% capacity. Securely replace the fuel cap and wipe up any spills.

WARNING

Gasoline is extremely flammable. Never smoke or vape anything near fuel. You must stop the engine and allow it to cool before refueling. Select outdoor bare ground for fueling and move the generator at least 3m (10 ft) away from the fueling point before starting the engine.

Gasoline can expand; do not fill the tank to the top. Leave at least 1.5 inches of open space. Gasoline fumes are explosive, never fill the tank near an open flame, and always check for spills.

To ensure smooth operation, use only fresh gasoline with an octane rating of 87. Never use old gasoline and avoid introducing dirt or water into the fuel tank. Gasoline ages in the tank, making future starts difficult. Do not store the generator for extended periods with gasoline in the tank.

Operation

Grounding the Generator

Attach a grounding wire if required by local code:

- Connect a suitable grounding wire to the grounding stud on the control panel and tighten the nut.
- Attach the other end to a copper or brass grounding rod driven into the earth.

A commonly acceptable grounding wire is a No. 12 AWG (American Wire Gauge) stranded copper wire. Since grounding codes vary by location, consult a local electrician to ensure compliance with local regulations.

Operating the Generator

Location: Do not operate the generator inside any building, garage, basement, crawlspace, shed, RV compartment, or other enclosed spaces.

Outdoor Setup: Avoid operating the generator in a truck bed, camper, trailer, or any other confined location, such as under staircases or next to walls, which may restrict airflow or exhaust.

Weather Conditions: Never operate or store the generator in wet conditions (e.g., rain or snow) to avoid serious injury or death from electrocution.

Clearances: Maintain a minimum of 5 feet (1.5 meters) of clearance from all combustible materials. Ensure at least 5 feet (1.5 meters) of airflow clearance on all sides for cooling, maintenance, and safe exhaust flow.

Ventilation: Position the generator in a well-ventilated area and away from air intake vents or confined spaces where exhaust fumes could enter.

Wind Direction: Be mindful of wind direction when positioning the generator to prevent exhaust from flowing toward occupied spaces.

Cooling: Allow the generator to cool fully before transporting or storing.

Failure to follow these safety precautions may result in personal injury, damage to the generator, and may void the manufacturer's warranty.

⚠ WARNING

During operation, the muffler and engine will be very hot. Without adequate cooling space or if the generator is blocked or enclosed, temperatures may rise quickly and could lead to a fire.

Starting the Generator

1. Make sure the generator is on a solid, flat, level surface.
2. Disconnect all electrical loads from the generator. Never start or stop the generator with electrical devices attached. Turn the fuel valve to the desired fuel source. When the valve is in the gasoline position, the generator is ready to start with gasoline. When the switch is in the LPG position, the generator is ready to start with propane.

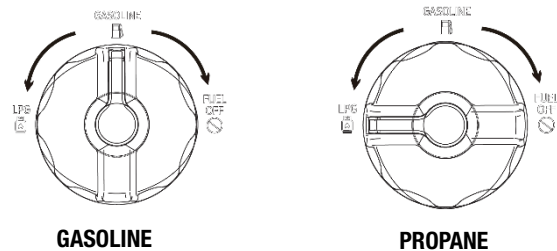

3. Turn OFF ECO Switch

The Economy Switch is located on the control panel. Switch it OFF to disable low idle when starting the generator.

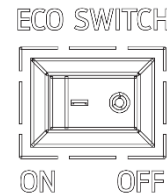

4. Turn ON Battery Switch

Press the Battery Switch up to the "ON" position to start the generator.

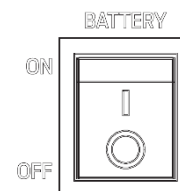

Operation

5. For Recoil Start

Recoil Start: Firmly grasp and pull the recoil handle slowly until you feel resistance, let it retract then pull swiftly. If it fails to start successfully, wait for 3 seconds then repeat this step.

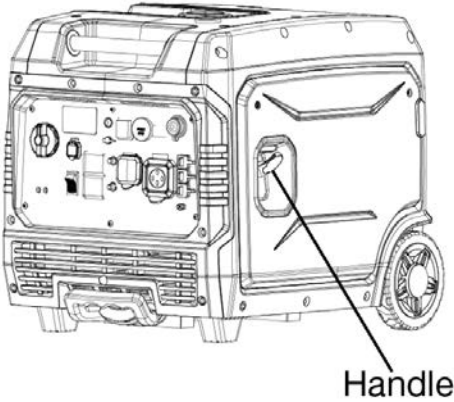

Engine Start/Stop: Press the start button once, the engine will attempt to start twice automatically. If it fails to start, press the start button again.

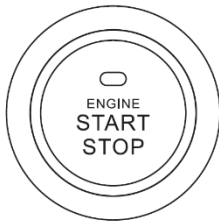

Remote Start: Push and hold the ON button on the remote start key fob for one second.

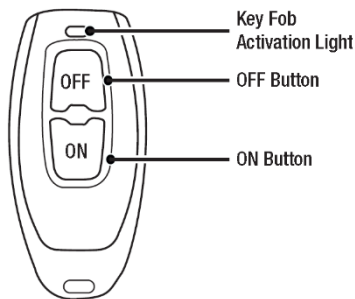

6. Plug in devices

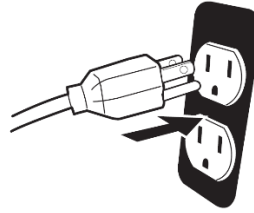

⚠ DANGER

Fire and explosion hazard. Always turn the propane tank valve to the fully closed position if not running the generator

⚠ WARNING

When using the generator with propane, make sure there is no possible ignition source close to the generator.

Gasoline To LPG

IMPORTANT: Load capacity is reduced when running on LPG. Ensure the generator can supply enough (running) and surge (starting) watts for the devices you are powering before switching to LPG.

1. Turn the LPG tank valve to the fully open position.
2. Turn the fuel selector valve to LPG.

NOTE: When switching to LPG operation the engine may run rough for a few seconds while it purges gasoline from the carburetor.

LPG To Gasoline

1. Turn the fuel selector valve to gasoline.
2. Turn the LPG tank valve to the fully closed position.

If the engine stops when switching fuel sources, disconnect all loads then restart the unit on the fuel source of choice.

Parallel Operation

The parallel connection ports allow you to connect two compatible generators to increase the total available electrical power. Follow the instructions included with your parallel connection kit for proper installation and operation.

Operation

Overload Indicator

Note: The OVERLOAD light may turn on briefly when starting a large device. This is normal for loads near the generator's capacity.

- Ensure the total combined load does not exceed the generator's running power.
- If the OVERLOAD light stays on and power stops, the generator is overloaded or may need service.
- Turn off and disconnect all devices, then stop the engine. Compare device requirements to generator rating and reduce wattage if necessary. Ensure proper ventilation around the generator.
- Check if any circuit breakers have tripped and reset all breakers before restarting.
- Restart the engine, reconnect devices, and avoid overloading.
- If this happens repeatedly, have the generator serviced by an authorized Pulsar service center.

Low Oil Indicator

1. If the engine oil level is too low, the LOW OIL light turns on, the engine will automatically shut off.
2. The engine cannot be restarted until the proper amount of oil has been added.

NOTICE

Do not run the engine with too little oil. Engine will shut off if engine oil level is too low.

Economy Switch

1. Turn the economy switch ON to limit noise and fuel consumption for lighter generator loads.
2. Turn the economy switch OFF to operate the engine at full speed when:
 - Starting the generator
 - A heavy load is applied

Stop the Engine

1. Turn off and unplug all connected electrical loads. Never start or stop the generator with electrical devices plugged in or turned on.

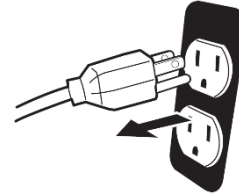

2. Press the OFF button for 1-3 seconds to stop the engine.

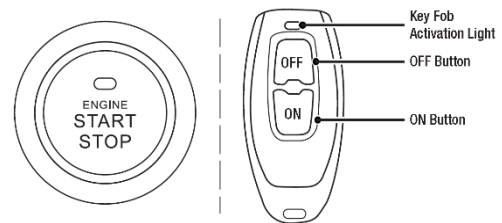

3. Turn OFF Battery Switch.

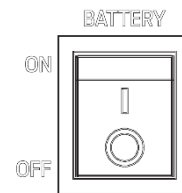

NOTICE

Generator Capacity

Do not exceed the generator's power capacity. Exceeding the wattage capacity can lead to damage to both the generator and the electrical devices connected to it.

Ensure that the generator can supply sufficient continuous (running) and surge (starting) watts for the devices you plan to power simultaneously.

Operation

When determining power requirements, consider the total power needs of all connected devices using the formula: **Volts x Amps = Watts**. Appliance and power tool manufacturers typically provide rating information near the model or serial number.

To determine power requirements:

1. **Select the Devices:** Identify the devices you intend to power simultaneously with the generator.
2. **Total Continuous Watts:** Calculate the total continuous (running) watts. This total represents the power the generator must deliver to keep all selected devices operational.
3. **Estimate Surge Watts:** Determine the estimated surge (starting) watts required. Surge wattage is the initial burst of power needed to start electric motor-driven tools or appliances, such as a circular saw or refrigerator. Since not all motors start at the same time, you can estimate total surge watts by adding the item(s) with the highest additional surge wattage to the continuous watt total from Step 2.

High Altitude Operation

Operating the generator at high altitudes can affect performance due to a richer air/fuel mixture, leading to decreased efficiency and increased fuel consumption. It may also cause spark plug fouling and hard starting. Extended operation at elevations different from the engine's certification may result in higher emissions.

For those using the generator above 5,000 feet (1,500 meters), a qualified technician should perform carburetor modifications to improve performance. While these modifications will help meet emission standards, note that engine power will decrease by approximately 3.5% for every 1,000-foot (300-meter) increase in elevation.

Maintenance

Safety Precautions Before Maintenance



Turn Off the Generator: Switch the generator to "OFF," wait for the engine to cool, and disconnect the spark plug cable before performing any inspections, maintenance, or cleaning.

Equipment Failure: Do not use damaged equipment. If you notice abnormal noise, vibration, or excessive smoke, correct the issue before further use.

Qualified Technician: Many maintenance tasks, including those not detailed in this manual, should be performed by a qualified technician to ensure safety. If you are unsure about servicing the equipment or engine, please contact an authorized Pulsar service center for assistance.

Cleaning, Maintenance, and Lubrication Schedule

This schedule serves as a general guide. If performance decreases or if the generator operates unusually, have it inspected immediately. Maintenance needs may vary based on factors such as duty cycle, temperature, air quality, and fuel quality.

The following procedures are in addition to the regular checks and maintenance outlined for the generator:

Before Each Use: Check engine oil level.

Every 3 Months or 50 Hours of Use: Clean or replace air cleaner.

Every 6 Months or 100 Hours of Use: Change engine oil. Check and clean the spark plug and spark arrestor. Check/adjust valve clearance.

Yearly or Every 300 Hours of Use: Clean fuel tank, strainer, and carburetor. Clean carbon build-up from the combustion chamber.

Every 2 Years: Replace fuel line if necessary.

Maintenance

Checking and Filling Fuel

WARNING

To Prevent Serious Injury from Fire: Always shut off the engine while refueling.

1. Clean the fuel cap and the area around it.
2. Unscrew and remove the fuel cap.
3. Remove the strainer and discard any dirt and debris, then replace the strainer.

NOTICE

Do not use gasoline containing more than 10% ethanol (E10) or E85 ethanol.

Add a fuel stabilizer (such as Sta-Bil or Pri-G) to the gasoline; failure to do so will void the warranty.

Avoid using gasoline that has been stored in a metal or dirty fuel container, as it can introduce particles that affect engine performance or cause damage.

4. Add fuel if needed, do not overfill.
5. Replace the fuel cap securely.
6. Wipe up any spilled fuel and allow any residue to evaporate before starting the engine. To prevent fire, do not start the engine while the smell of fuel lingers in the air.

Air Filter Maintenance

1. Remove the air filter case cover.
2. Take out the foam element.
3. Wash the foam element in hot, soapy water. Never use a solvent.
4. Completely dry the foam element before reinstalling it.

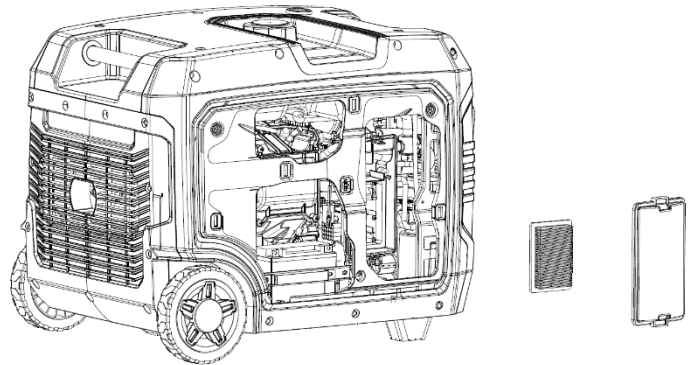

NOTICE

Do not wring out the foam element as this could cause it to tear.

1. Apply a few drops of clean engine oil to the foam element and work it into the foam element. The foam should have a light coating, not dripping. Ensure the oil is evenly distributed for a light film across the foam material.
2. Reinstall the foam element in the air filter box. The engine should never run without the foam element, as premature engine wear may result.
3. Install the air filter case cover in its original position.

Spark Plug Maintenance

The spark plug is critical for good engine performance; it should be removed, cleaned, inspected, adjusted, and/or replaced regularly to maintain optimal performance.

1. **Remove the left side panel.**
2. **Remove the Spark Plug:** Remove the spark plug access cover (①) and then the spark plug boot (②). Insert the spark plug tool through the hole and fit it securely over the spark plug. Use the T-handle (④) through the spark plug wrench (③) and turn it counterclockwise until the spark plug can be removed.

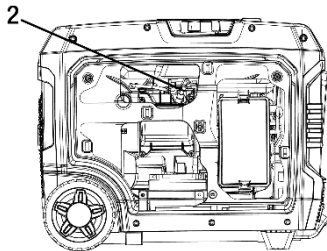
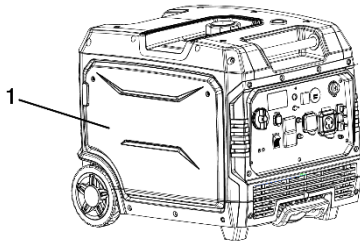

- Inspect and Clean:** Check the porcelain insulator nose; it should be a light tan color. Use a wire brush to remove any black carbon deposits. Measure the spark plug gap. Adjust the gap or replace the spark plug as necessary, ensuring the gap is measured with a wire thickness gauge.
- Reinstall the Spark Plug:** Tighten the spark plug to 12.5 N·m (15 lb·ft). Proper tightening is crucial: If the spark plug is too loose, it can cause the engine to overheat. If it is over-tightened, it may damage the threads in the cylinder head.

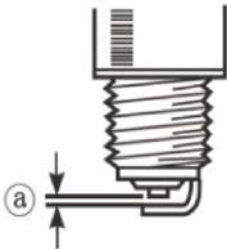

Standard Spark Plug: F7TC
Spark Plug Gap: 0.6-0.8 mm

NOTICE

If a torque wrench is not available, a good estimate of the correct torque is 1/4 to 1/2 turn past finger tight. However, the spark plug should be tightened to the specified torque as soon as possible.

- Reconnect the Spark Plug Boot:** Ensure it clicks into place. Tug gently on the boot to confirm a secure connection.
- Reinstall the Spark Plug Cover.**

Generator Storage

When the generator will remain idle for longer than 30 days, prepare the engine for storage as follows:

- Cleaning:** Allow the engine to cool. Open both side access panels and blow or vacuum any dirt or debris. Do not use water for cleaning, as it can enter the engine and cause damage.
- Fuel Treatment/Draining:** Fill the fuel tank with fresh gasoline that has been treated with a fuel stabilizer additive (such as Sta-Bil or Pri-G). Follow the fuel stabilizer manufacturer's recommendations for use.
- Storage Area:** Cover the generator and store it in a dry, level, well-ventilated area out of reach of children, away from ignition sources like water heaters and furnaces.
- Engine Operation During Storage:** Start the engine every 3 months and allow it to run for 15-20 minutes.

⚠ WARNING

Fill the fuel tank in a well-ventilated area away from ignition sources. If the engine is hot from use, allow it to cool before adding fuel. Do not smoke or vape while refueling.

Draining the Carburetor

- Shut off the gasoline flow.
- Place an appropriate container under the carburetor.
- Carefully open the drain screw at the bottom of the carburetor bowl, allowing the fuel to drain completely.
- Retighten the screw after draining.

NOTICE

Aged gasoline that has not been treated with a stabilizer must be safely drained and disposed of. Never run old gasoline through the engine. To prevent serious injury and fire, ensure the engine is cool before performing any maintenance procedures.

Specifications

Product Description	7600W Gasoline Inverter Generator
Engine Type	Single Cylinder, 4-Stroke, Forced Air Cooling, Gasoline Engine, OHV
Displacement (cc)	298
Peak Power (Gasoline)	7600W
Peak Power (Propane)	6900W
Rated Power (Gasoline)	6300W
Rated Power (Propane)	5700W
Consumption at Half Load (Gasoline)	1.87L/h, 0.49gal/h
Fuel Tank Capacity (gal)	15L/3.96gal
Run Time at Half Load (hour)	8h
Voltage Rating	120/240V
Rated Frequency	60Hz
Amperage (120V Rated/Peak)	52.5/63.3
Amperage (240V Rated/Peak)	26.3A / 31.7A
Starting Type	Recoil, Electric Start, and Remote
Outlet	2*AC 120V 20A, 1*AC 120V 30A, 1*AC 120/240V 50A, 1*USB-A, 1*USB-C
Oil Type	SAE 10W-30
Oil Capacity	650ml (22 fl oz)
Maximum Ambient Temperature	40°C (104°F)
Product Dimensions (in)	27 x 20.8 x 21.7
NW (lbs)	133.4
Warranty	3 Years

Troubleshooting Guide

Problem	What to Do
THE ENGINE WILL NOT START	Check Fuel Level: Ensure there is enough gasoline in the tank.
	Fuel Filter Check: If the fuel filter is clogged, replace it with a new one.
	Check Oil Level: Make sure the oil level is at the full mark. Low oil can prevent starting in generators with a low oil shutdown feature.
	Spark Plug Condition: Remove and inspect the spark plug. Clean or replace if it appears fouled or worn. Ensure the spark plug cap is securely attached.
	Air Filter: Check the air filter for dirt or blockages. Clean or replace if necessary.
	Inspect Fuel Quality: Use fresh gasoline with an octane rating of 87. Stale fuel may need to be drained and replaced.
	Carburetor Issues: If the carburetor is fouled, it may require cleaning or servicing.
	Ignition System: If the ignition system seems faulty, consult an authorized service center.
	Fuel Valve Position(Gasoline): Ensure the fuel valve is set to the "Gasoline" position. If it's off, or set to LPG gasoline won't flow to the carburetor, preventing the engine from starting.
Fuel Valve Blockage: If the fuel valve is open but no fuel is reaching the carburetor, the valve or fuel line could be clogged. Cleaning or replacing the fuel valve may be necessary.	

Troubleshooting Guide

Problem	What to Do
<p style="text-align: center;">GENERATOR WILL NOT PRODUCE POWER</p>	<p>Check Circuit Breakers: Ensure all circuit breakers are in the "ON" position. If any are tripped, reset them and test for power.</p>
	<p>Verify Connections: Make sure all power cords are connected securely and that any connected devices are operational.</p>
	<p>Inspect for Overload: If the generator was overloaded, disconnect all devices and let it run briefly to reset. Reconnect devices gradually, staying within the generator's rated capacity.</p>
	<p>Check for Overload Indicator Light: If your generator has an overload indicator, make sure it isn't lit. An overload light often signals that a high-powered device is drawing too much electricity.</p>
	<p>Examine the Outlet Panel: Inspect the outlets for damage or debris, as these can prevent proper electrical flow.</p>
	<p>Reset the Generator: Some inverter generators have reset buttons. Follow the user manual to reset the inverter if applicable.</p>
	<p>Professional Service: If none of the above steps restore power, it could be an issue with internal components (e.g., alternator or inverter module), and you may need to contact a Pulsar service center for repair.</p>

Electrical Schematic

