

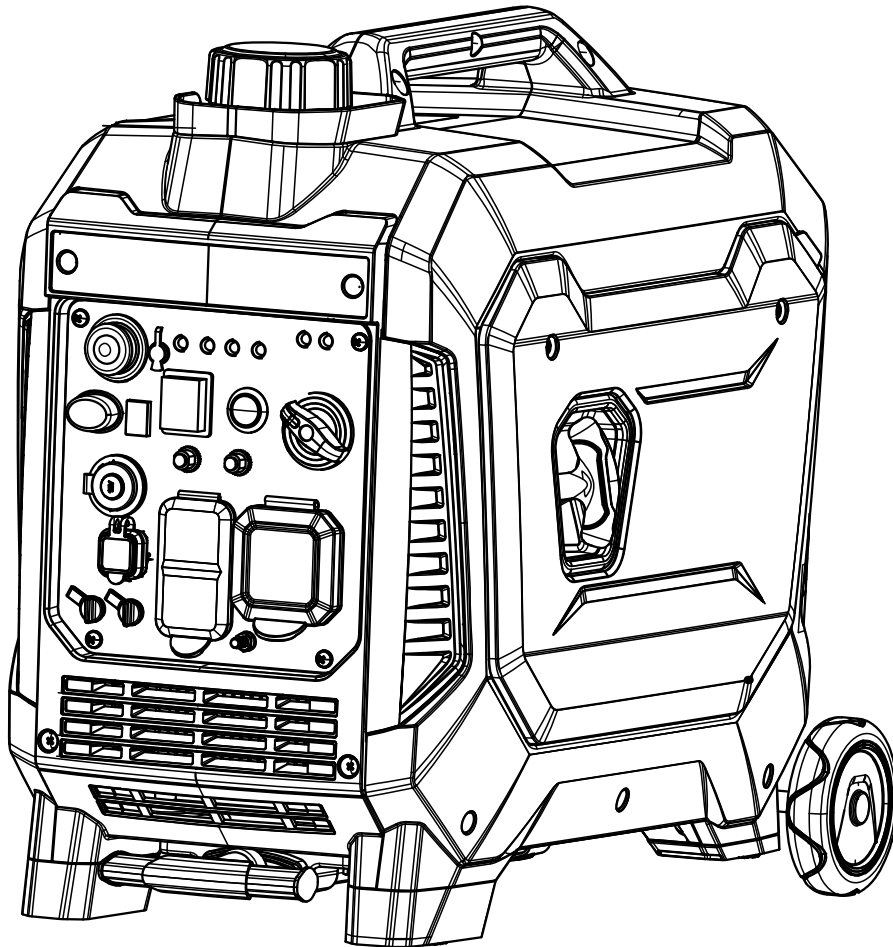

Model: PG4000BiSRCO

4000 Watt Dual-Fuel Inverter Generator  
OPERATOR'S MANUAL



Warning: The Engine Exhaust from this product contains chemicals known to the State of California to cause cancer, birth defects or other reproductive harm.



	<b>DO NOT RETURN TO STORE!</b>
	HAVE QUESTIONS OR NEED SERVICE?
866-591-8921	support@pulsar-products.com

# Table of Contents

Safety Warnings. . . . .	1	Preparation. . . . .	12
Safety Instructions. . . . .	2	Adding Engine Oil. . . . .	12
CO Sentry. . . . .	5	Connecting LPG Tank . . . . .	12
Names of Components. . . . .	6	Battery. . . . .	12
Control Panel . . . . .	7	Operation . . . . .	16
Specifications . . . . .	8	Maintenance . . . . .	20
Assembly . . . . .	9	Troubleshooting . . . . .	24

## Introduction

Thank you for choosing Pulsar Products!  
This manual provides instruction on how to operate and use your generator safely and correctly; be sure to read and understand this manual before using your generator. If you have ANY questions, please phone 866.591.8921 M-F or support@pulsar-products.com BEFORE using your generator.

All details and images in this Manual are believed to be accurate at the time of publication.

Pulsar Products reserves the right to make updates to this manual at any time.

Please contact Pulsar Support at **866.591.8921** or **support@pulsar-products.com** for the latest updates.

This manual is a permanent part of the generator set. If the generator is resold, kindly include this manual with the generator.

## Safety Warnings and Notices

### WARNING: Save This Manual For Future Reference

This manual contains important information regarding the safety, operation, maintenance, and storage of this product. Before use, read carefully and understand all cautions, warnings, instructions, and product labels. Failure to do so could result in serious personal injury and/or property damage.

## Safety Definitions

The words DANGER, WARNING, CAUTION, and NOTICE are used throughout this manual to highlight important information. Make sure that the meaning of this safety information is known to all who operate, perform maintenance on, or are near the generator.

 This safety alert symbol appears with most safety statements. It means to pay attention and be alert, your safety is involved! Please read and abide by the message that follows the safety alerts symbol.

### DANGER

DANGER indicates an imminently hazardous situation which, if not avoided, will result in death or serious injury.

### WARNING

WARNING indicates a potentially hazardous situation which, if not avoided, could result in death or serious injury.

### CAUTION

CAUTION indicates a potentially hazardous situation which, if not avoided, may result in minor or moderate injury. It may also be used to alert against unsafe practices.

### NOTICE











Failure to follow the instruction may result in the damage to your generator and other property.

## Safety Symbols

Follow all safety information contained in this manual and on the generator.

# Safety Instructions

Before operating your generator, you must read and understand the manual and familiarize yourself with the safe operation practices.

SYMBOL	DESCRIPTION
	Safety Alert Symbol
	Electrocution Hazard
	Asphyxiation Hazard
	Burn Hazard. DO NOT touch hot surfaces.
	Electrical Shock Hazard
	Fire Hazard
	Maintain Safe Distance
	Lifting Hazard
	Read Manufacturer's Instructions
	DO NOT Operate in Wet Conditions
	Ground. Consult with electrician to determine grounding requirements before

## Safety Precautions

### DANGER

Using a generator indoors **CAN KILL YOU IN MINUTES**. Generator exhaust contains carbon monoxide. This is a poison you cannot see or smell.



**NEVER** use inside a home or garage, **EVEN IF** doors and windows are open.



**ONLY** use **OUTSIDE** and far away from windows, doors, and vents.

### WARNING

**POISONOUS GAS HAZARD:** Engine exhaust contains carbon monoxide, a poisonous gas that could kill you in minutes. You **CAN NOT** smell it, see it, or taste it. Even if you do not smell exhaust fumes, you could still be exposed to carbon monoxide gas.

Operate this product **ONLY** outside far away from windows, doors, and vents to reduce the risk of carbon monoxide gas from accumulating and potentially being drawn towards occupied spaces.

Install battery-operated carbon monoxide alarms or plug-in carbon monoxide alarms with battery backup according to the manufacturer's instructions. Most smoke alarms cannot detect carbon monoxide gas.

**DO NOT** run this product inside homes, garages, basements, crawlspaces, sheds, or other partially enclosed spaces even if using fans or opening doors and windows for ventilation. Carbon monoxide can quickly build up in these spaces and can linger for hours, even after this product has shut off.

**ALWAYS** place this product downwind and point the engine exhaust away from occupied spaces. If you start to feel sick, dizzy, or weak while using this product, shut it off and get to fresh air **IMMEDIATELY** - then see a doctor; you may have carbon monoxide poisoning.

# Safety Instructions

## Correct Usage

Example location to reduce risk of carbon monoxide poisoning

- **ONLY** use outside and downwind, far away from windows, doors, and vents.
- Direct exhaust away from occupied spaces.



## Incorrect Usage

Do not operate in any of the following locations:

- Near any door, window, or vent
- Garage
- Basement
- Crawl Space
- Living Area
- Attic
- Entry Way
- Porch
- Mud Room

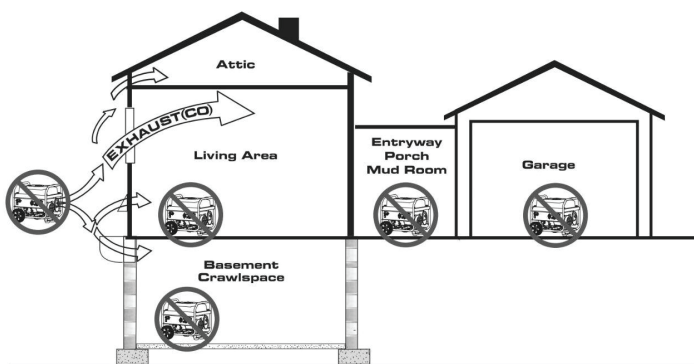

## WARNING

Starter cord kickback (rapid retraction) could pull hand and arm toward the engine faster than you can let go which could cause broken bones, fractures, bruises, sprains, or other serious injuries.

## WARNING



Fuel and its vapors are extremely flammable and explosive which could cause burns, fire, or explosion resulting in death or serious injury and/or property damage.

## When Adding Or Draining Gasoline

Turn the generator engine OFF and let it cool for at least 2 minutes before removing the fuel cap. Loosen the cap slowly to relieve pressure in the tank.

- Fill or drain fuel tank outdoors.
- DO NOT overfill the tank. Allow space for fuel expansion.
- If fuel spills, wipe it up and let the area dry before starting the engine.
- Keep fuel away from sparks, open flames, heat, and other ignition sources.
- Check fuel lines, tank, cap, and fittings frequently for cracks or leaks; replace if necessary.
- DO NOT light a cigarette or smoke anything.

## When Starting Equipment

- Ensure spark plug, muffler, fuel cap, and air cleaner are in place.
- DO NOT crank engine with spark plug removed.

## When Operating Equipment

- DO NOT operate this product inside any building, carport, porch, mobile enclosure, marine applications, or shed.
- DO NOT tip engine or equipment at an angle that causes fuel to spill.
- DO NOT stop the engine by moving the choke control to the "Start" position.
- DO NOT exceed the generator's wattage capacity.
- Start the generator and let the engine stabilize before connecting electrical loads.
- Connect electrical loads in the OFF position, then turn ON for operation.
- Turn electrical loads OFF and disconnect from the generator before stopping the generator.

# Safety Instructions

## NOTE

Improper treatment of the generator could damage it and shorten its life.

- Use generator only for intended applications.
- If you have questions about intended use, ask a dealer or contact your local Pulsar service center.
- Operate generator only on solid, level surfaces.
- DO NOT expose the generator to excessive moisture, dust, dirt, or corrosive vapors.
- DO NOT insert any objects through cooling slots.
- If connected devices overheat, turn them off and disconnect them from the generator.

Shut off the generator if:

- Electrical output is lost.
- Equipment sparks, smokes, or emits flames.
- Unit vibrates excessively.

## Parallel Kit Precautions



To prevent serious injury, death, and generator and/or equipment damage from electric shock and fire:

1. Follow Parallel Kit instructions provided with it for connection and use of a Parallel Kit.
2. Only connect two identical Inverter Generators together using a Parallel Kit.
3. Connect Parallel Kit only to terminals marked "Parallel" on the front of the Generator.
4. Do not remove or connect a Parallel Kit while the Generator is running.
5. Do not use a Parallel Kit that is attached to only one Generator.

## Carbon Monoxide Safety

### Carbon Monoxide

Generators are very convenient, but they can also be very dangerous. All fuel-burning appliances and equipment release a poisonous gas called carbon monoxide. Carbon monoxide (also known as CO) can be dangerous for humans and pets, even in small amounts, because it blocks oxygen from getting into your body. Carbon monoxide poisoning can lead to death in a very short time. It is odorless, tasteless and invisible, so you may be exposed without knowing it. That is why carbon monoxide is sometimes called "the silent killer."

## CO Sentry

The CO Sentry system was created to protect from dangerous carbon monoxide. Just like the detector for your home the CO Sentry tests the air for dangerous levels of carbon monoxide. If dangerous levels of carbon monoxide are detected this generator will automatically shut off.



Automatic shut off accompanied with a flashing RED light in the CO Sentry portion of the control panel is an indication that the generator was improperly located. If you start to feel sick, dizzy, weak, or carbon monoxide detectors in your home indicate an alarm, get to fresh air immediately. Call emergency services. You may have carbon monoxide poisoning.

## CO Sentry Indicator Lights

### RED

Carbon monoxide has accumulated around the generator. After shut off, the RED indicator light in the CO Sentry area of the control panel will flash to provide notification that the generator was shut off due to an accumulating CO hazard. The RED light will flash for at least five minutes after a CO shut off. Move the generator to an open, outdoor area far away from occupied spaces with exhaust pointed away. Once relocated to a safe area, the generator can be restarted. Introduce fresh air and ventilate the area where the generator had shut down.

### YELLOW

A CO Sentry system fault occurred. When a system fault occurs, the generator is automatically shut down and the YELLOW indicator light in the CO auto shut off area of the control panel will flash to provide notification that a fault has occurred. The YELLOW light will flash for at least five minutes after a fault. The generator can be re-started, but may continue to shut off.



# Components

Before operating your generator, you must read and understand the manual and familiarize yourself with the safe operation practices.

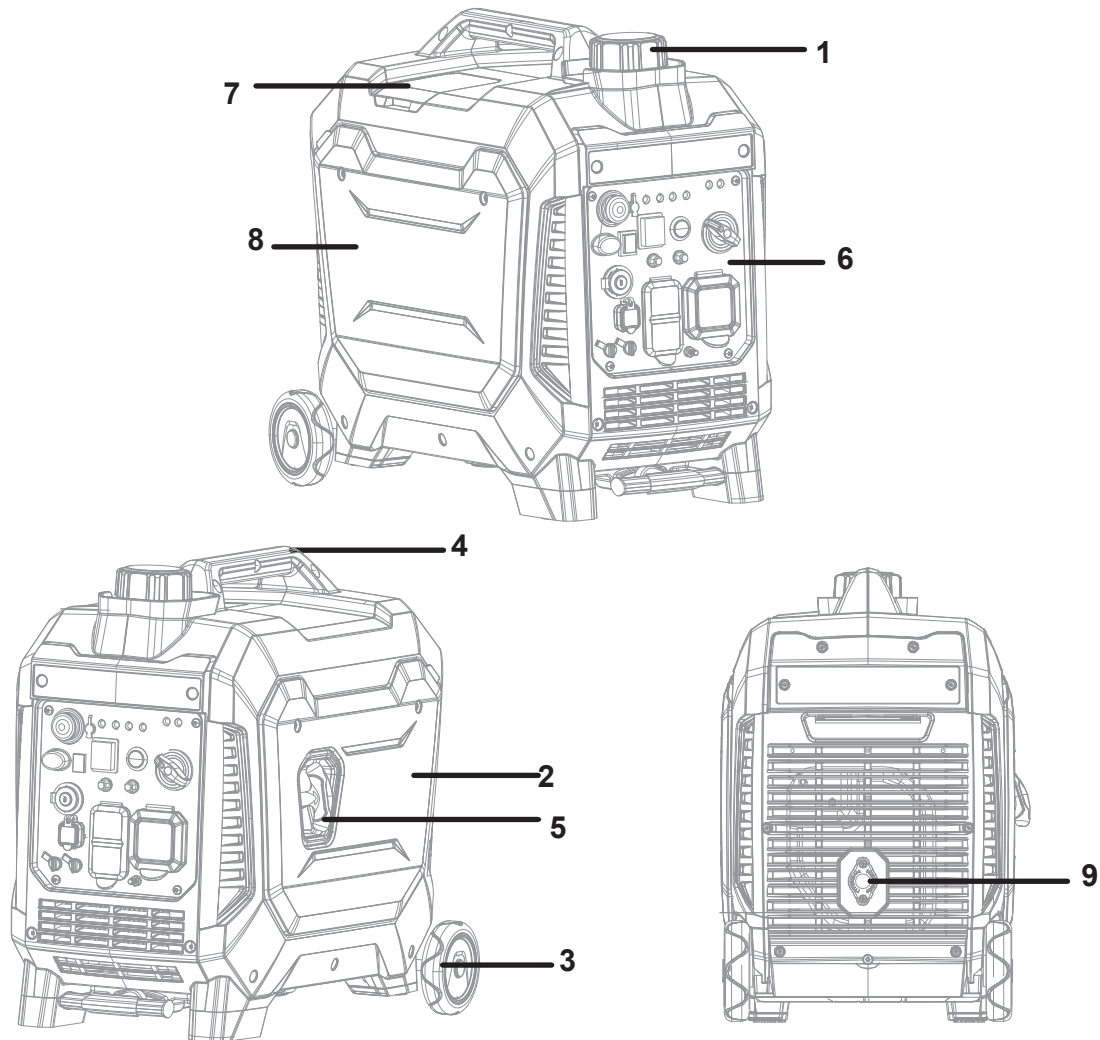

1. **Fuel Cap:** Add gasoline here.
2. **Right Side Panel:** Engine, air filter, carburetor, dipstick, and drain plug, can be found after removing the right side panel.
3. **Transport Wheels:** Wheels allow one-handed maneuverability when used with the extendable handle.
4. **Carry Handles:** Helps transport the generator.
5. **Recoil Handle:** Pull the recoil handle to manually start the engine.
6. **Control Panel:** The control panel contains the outlets and operational controls.
7. **Spark Plug Cover:** Spark plug can be maintained after removing this cover.
8. **Left Side Panel:** Battery and quick connection plug can be accessed by removing this panel.
9. **Muffler and Spark Arrestor:** The spark arrestor prevents sparks from exiting the muffler.



# Control Panel

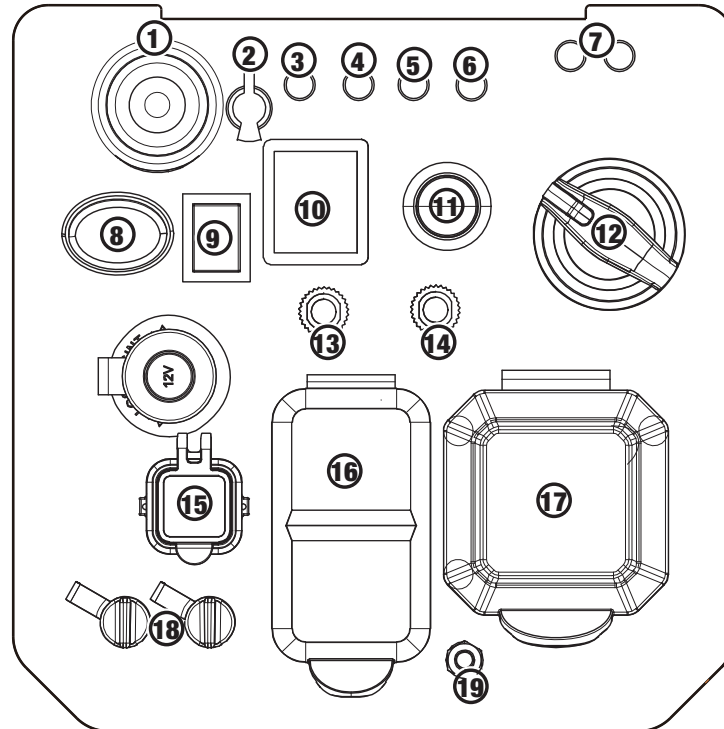

**1. Propane Inlet:** Connect the propane hose (included) to this inlet.

**2. Battery Charging Port:** Used to charge the battery with the included battery charger.

**3. Output Ready LED:** Illuminates when the generator is operating normally. Indicates the generator is producing power.

**4. Overload LED:** Indicates that the generator is overloaded.

**5. Low Oil LED:** Indicates low oil level. When the oil level in the crankcase falls below the safe operating limit, the low oil level indicator will illuminate and the generator will automatically shut off the engine.

**6. Start Indicator:** Indicates the generator is running.

**7. CO Sentry Indicator Lights:** The CO Sentry monitors the accumulation of poisonous carbon monoxide gas. If increasing levels of CO gas are detected, the CO Sentry automatically shuts down the engine.

**8. Eco Mode:** Eco mode minimizes fuel consumption and noise by adjusting the engine RPM to the minimum required for the current load.

**9. LED Switch:** Illuminates the control panel.

**10. Battery Switch:** Turns battery ON and OFF. Must be ON before electric start or remote start.

**11. Push Button Start/Stop:** Push once to automatically start the engine. Push again to stop the engine.

**12. Fuel Selector Switch:** Used to select gasoline or propane.

**13. 12 Volt DC Breaker**

**14. 20 Amp AC Circuit Breaker:** Circuit breaker limits the current that can be delivered through the NEMA 5-20R receptacle to 20 Amps.

**15. USB Ports:** USB Type A 5V/3.6A, 9V/2.5A, 12V/2A and USB Type C.

**16. 120 Volt AC, 20 Amp Duplex NEMA 5-20R Receptacle:** The receptacle can supply a maximum of 20 Amps.

**17. 120 Volt AC, 30 Amp NEMA TT-30R Receptacle:** This receptacle can supply a maximum of 30 Amps.

**18. Parallel Connectors:** A compatible Pulsar Inverter Generator can be connected for additional power output.

**19. Ground Terminal:** The ground terminal is used to externally ground the generator.

## Specifications

Model	PG4000BiSRCO
Engine Type	Single Cylinder, Four Stroke, Air Cooled Gasoline Engine
Displacement	141cc
Rated Power (kW) Gasoline	3.2
Peak Power (kW) Gasoline	4.0
Rated Power (kW) LPG/Propane	2.8
Peak Power (kW) LPG/Propane	3.6
Rated Voltage	120V
Rated Frequency	60Hz
Phase	Single Phase
Starting Type	Recoil, Electric Start, and Remote
Fuel Type	Regular Gasoline
Fuel Capacity	1.66 Gallons
Total Harmonic Distortion	≤ 3%
Oil Type	10w-30
Oil Capacity	.040l (13.5 fl. Oz)
Maximum Ambient Temperature	104°F (40° C)



# Assembly

## Preparation

Your generator requires some assembly. This generator ships from our factory without oil; it must be properly filled with oil before operation.

## Unpacking

1. Set the shipping carton on a solid, flat surface.
2. Remove everything from the carton except the generator.
3. Using the carrying handles of the unit, carefully remove the generator from the box (minimum two people lifting is required).

## Packing List

Check all loose parts to the following list. Contact your dealer if any loose parts are not included.

### ① 2 xWheels

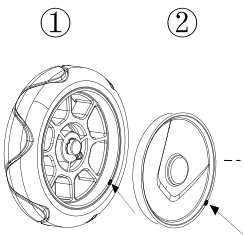

### ② 2 xWheel Covers

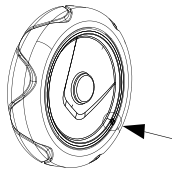

### ③ 2 xRubber Blocks

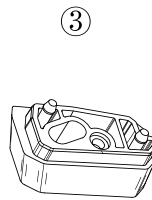

### ④ 1 xAxle

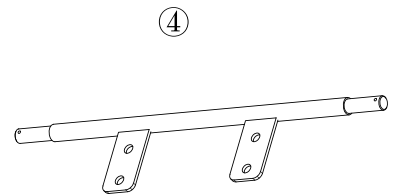

### ⑤ 2 xBolts(M6x16)

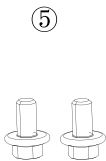

### ⑥ 6 xBolts(M6x12)

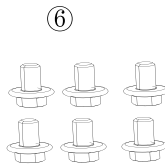

### ⑦ 2 xCotter Pins



### ⑧ 2 xWashers



### ⑨ 1 xTelescoping Handle

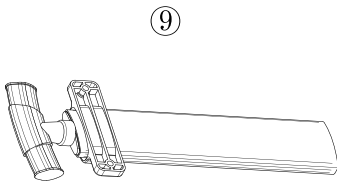

### ⑩ 1 xClamp



#### Extra Hardware

- ⑤ Bolts(M6×16) -2pc
- ⑥ Bolts(M6×12) -2pc
- ⑦ Cotter Pins -2pc
- ⑧ Washers -2pc

Note: Extra hardware is for spare use only.

#### Other auxiliary Parts

- Remote
- Charger
- Warranty Card
- Operator's Manual
- Spark Plug Wrench
- Funnel
- Dual-Use Screwdriver
- Fixed wrench
- Oil bottle

# Assembly

## Wheel set assembly (See Fig 1)

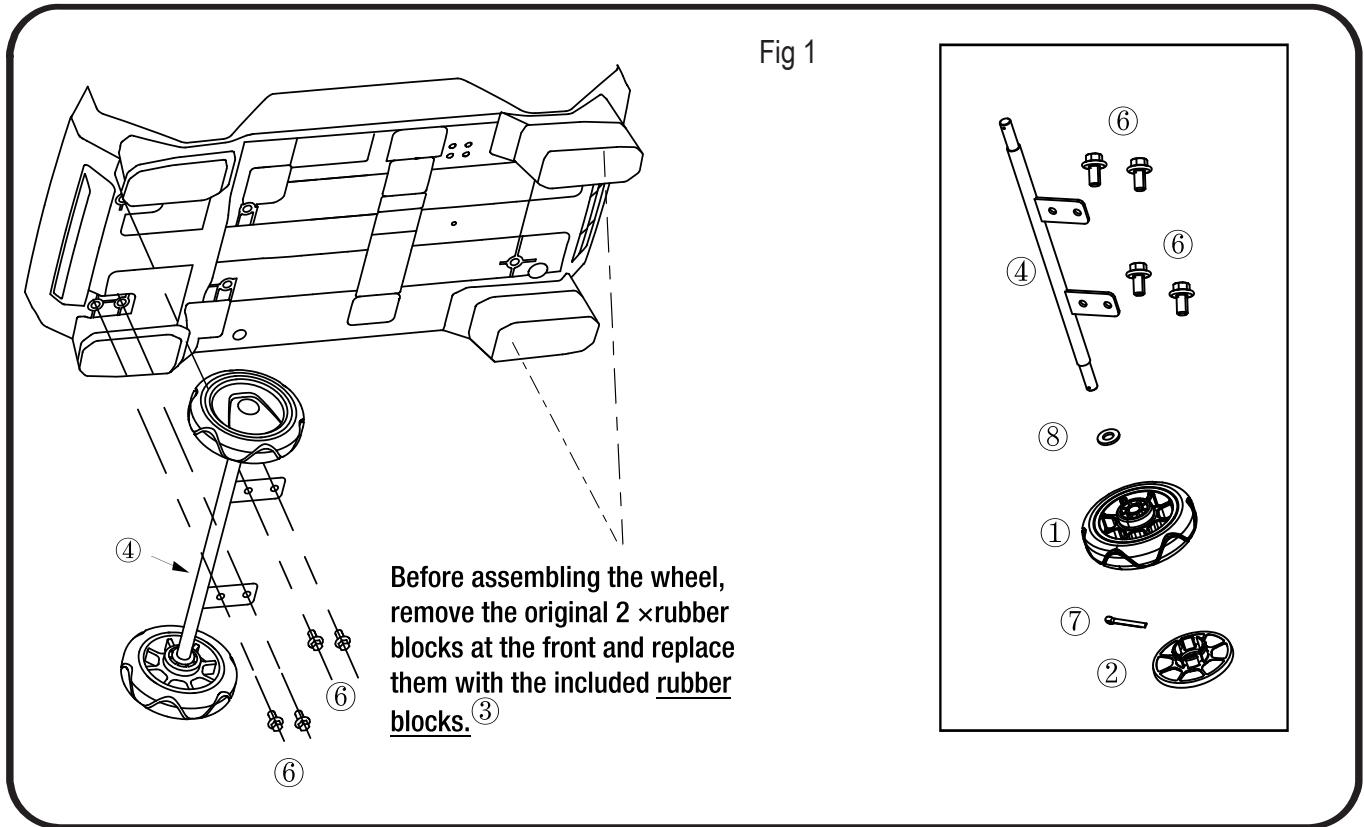

1. Locate the four threaded holes on the bottom frame of the generator where the axle brackets will be attached. Using the provided bolts, secure the axle brackets to the frame. Tighten the bolts with a wrench.
2. Slide a wheel onto each end of the axle. Place a washer on the outside of each wheel.
3. Secure the wheel with cotter pin through the hole at the end of the axle, and cover the wheel with part. Spread the legs apart to secure the cotter pin.
4. There are alignment marks on the wheel covers and wheels, align those marks and snap the wheel cover in place. (See Fig 2)
5. Repeat this process (from step 2) to install the other wheel.

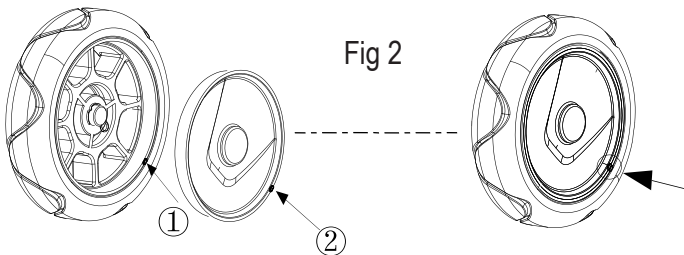

# Assembly

## Telescoping Handles assembly (See Fig 3)

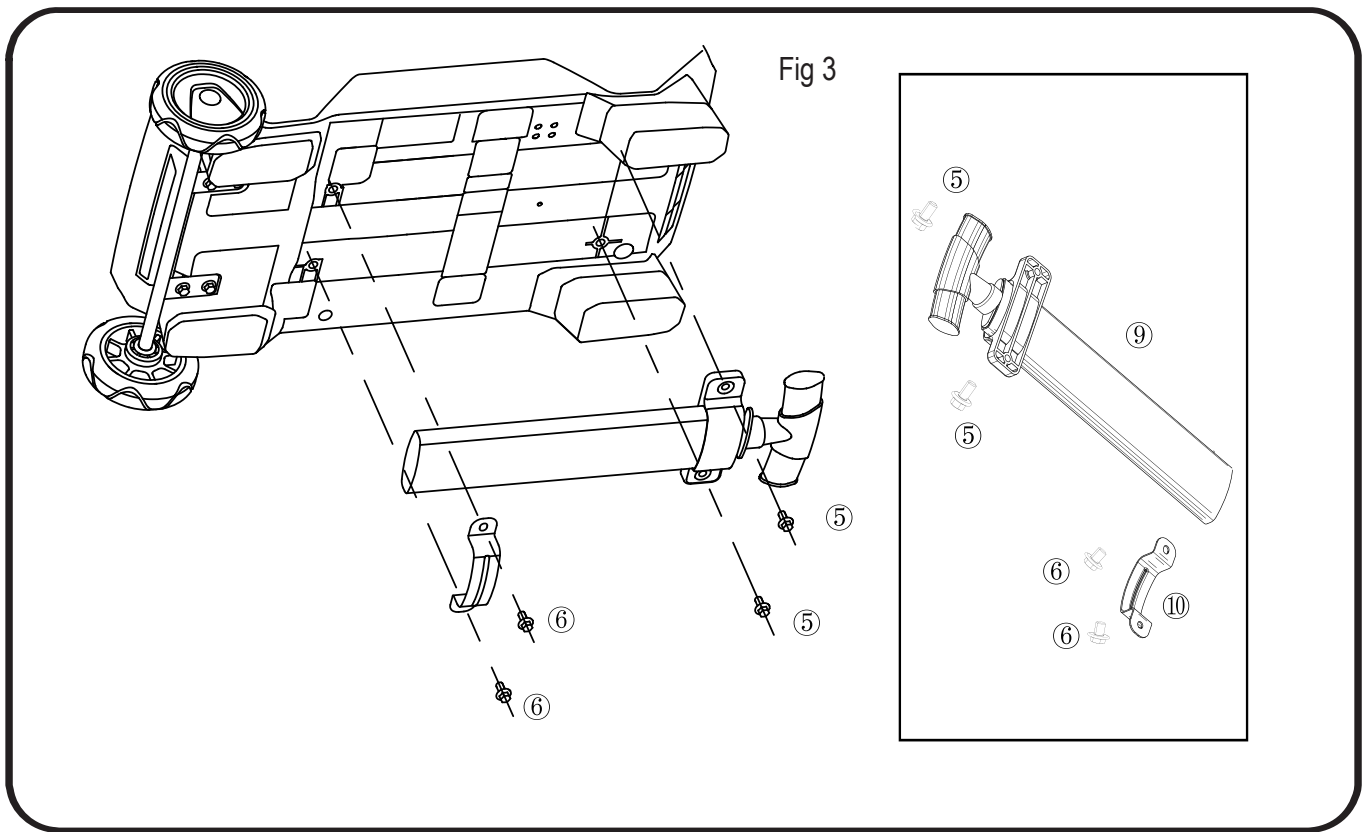

1. Align both handle clamps with the threaded holes on the base of the generator.
2. Insert the ⑤ bolt through the top handle bracket, and install the ⑥ bolts through the bottle handle bracket and into the corresponding thread holes.
3. Tighten the bolts securely using a wrench.

# Preparation

## Preparation

Your generator requires some assembly. This generator ships from our factory without oil; it must be properly filled with oil before operation.

## Unpacking

1. Set the shipping carton on a solid, flat surface.
2. Remove everything from the carton except the generator.
3. Using the carrying handle of the unit, carefully remove the generator from the box (two people lifting is recommended).

## Add Engine Oil

### ⚠ CAUTION

DO NOT attempt to crank or start the engine before it has been properly filled with the recommended type and amount of oil. Damage to the generator from failing to follow these instructions will void your warranty.

### NOTICE

Failure to follow this instruction may result in the damage to your generator and other property.

If running the generator in extreme temperatures, refer to the following chart for recommended oil type.

Recommended Engine Oil Type										
		10W-30								
		5W-30				10W-40				
		5W-30 Synthetic								
°F	-20	0	20	40	60	80	100	120		
°C	-28.9	-17.8	-6.7	4.4	15.6	26.7	37.8	48.9		
	Ambient temperature									

1. Place the generator on a solid, flat, level surface.
2. On the right side of the generator, loosen the screws and remove the maintenance cover.

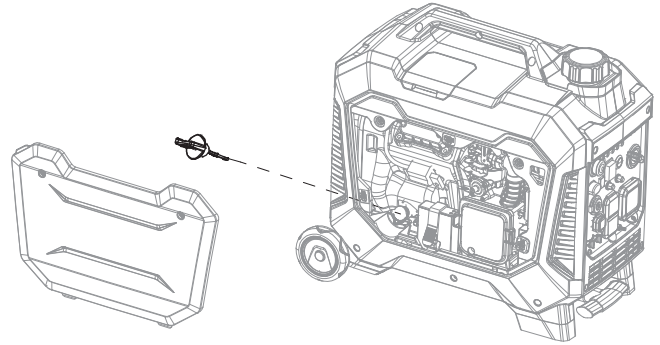

3. Remove oil fill cap/dipstick to add oil.
4. Using a funnel, add the appropriate type of oil until the oil level is at the proper level. SAE 10W-30 oil is recommended for general use. DO NOT OVERFILL. Replace oil fill cap/dipstick and secure maintenance cover.

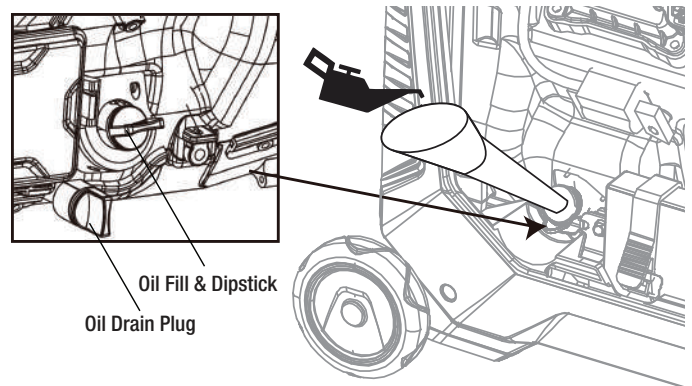

5. Check engine oil level before each use, and add as needed.

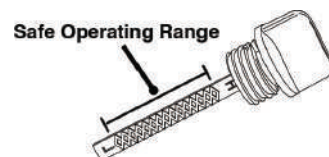

### NOTICE

Residual oil from the factory may remain in the engine, add oil slowly to prevent overfilling of the engine.

Once the oil has been added, oil level should appear 1-2 threads below the fill hole. DO NOT screw in the dipstick while checking.

# Preparation

## NOTICE

Check oil level often during the break-in period. Refer to the Maintenance section for recommended service intervals.

## CAUTION

This engine is equipped with a low oil shut-off and will stop when the oil level in the crankcase falls below a critical level.

## NOTICE

The first 5 hours of run time are the break-in period for the generator. During the break-in period stay at or below 50% of the running watt rating and vary the load occasionally to allow stator windings to heat and cool. Adjusting the load will also cause the engine speed to vary slightly and help seat the piston rings. After the 5-hour break-in period, change the oil.

## NOTICE

Synthetic oil may be used after the 5-hour initial break-in period. Using synthetic oil does not increase the recommended oil change interval. Full synthetic 5w-30 oil will aid in starting in cold < 41° F (5° C) temperatures.

## Add Gasoline

## WARNING



TO PREVENT SERIOUS INJURY FROM FIRE:

Fill the gasoline tank in a well-ventilated area away from ignition sources. If the engine is hot from use, shut the engine off and wait for it to cool before adding gasoline. Do not smoke.

1. Make sure the generator is on a solid, flat, level surface.
2. Unscrew the fuel cap and set it aside.
3. Slowly add gasoline to the fuel tank. Be careful not to overfill.

The fuel gauge on the top of the fuel tank indicates how much gasoline is in the generator fuel tank.

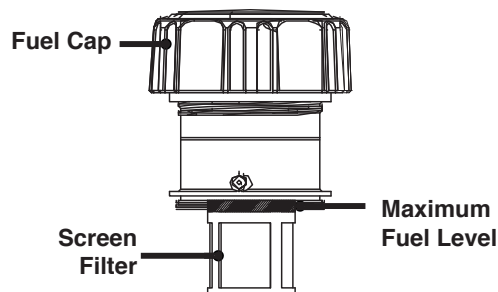

4. Replace the fuel cap and wipe up any spilled gasoline with a dry cloth then remove the cloth from the area.

## DANGER

Do not overfill the gasoline the tank. Overfilling can result in a fire, explosion, or death.

## WARNING

Gasoline can expand. Do not fill the gasoline tank to the top. Leave a minimum of 1.5 inches open space. Gasoline fumes are explosive. Do not fill the tank near an open flame. Always check for gasoline spills.

- To ensure that the generator runs smoothly use only FRESH, FRESH GASOLINE WITH AN OCTANE RATING OF 87.
- Never use old gasoline.
- Avoid getting dirt or water in the gasoline tank.
- Gasoline WILL age in the tank and make it hard to start the generator in the future.
- Never store generator for extended periods of time with gasoline in the tank.

## Connecting a Propane Tank

## NOTICE

- Propane tanks that use liquid withdrawal system can not be used on these models.
- Confirm that the re-qualification date on the tank has not expired.
- DO NOT use included LPG hose for any other appliances.

# Preparation

## NOTICE

- All new propane tanks must be purged of air and moisture prior to filling. Used propane tanks that have not been plugged or kept closed must also be purged. The purging process should be done by a propane tank supplier (propane tanks from an exchange supplier should have been purged and filled properly).
- ALWAYS position the propane tank so the connection between the valve and the gas inlet will not cause sharp bends or kinks in the hose.

## WARNING

Explosion hazard. DO NOT start generator if you smell propane. ALWAYS fully close the propane tank valve and disconnect the LPG hose from the generator when not in use. Never invert (turn upside down) a LPG tank while in use.

1. Turn the generator OFF and leave on a flat surface in a well ventilated area.
2. Verify that the propane tank valve is in the fully closed position.

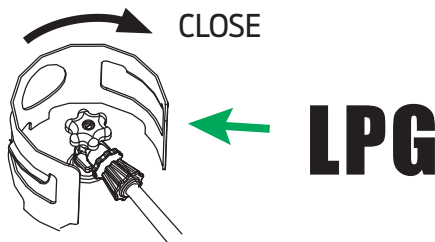

3. Remove the cover on the generator propane inlet.
4. Use your fingers to hand thread the LPG hose (included) to the propane inlet on the generator.

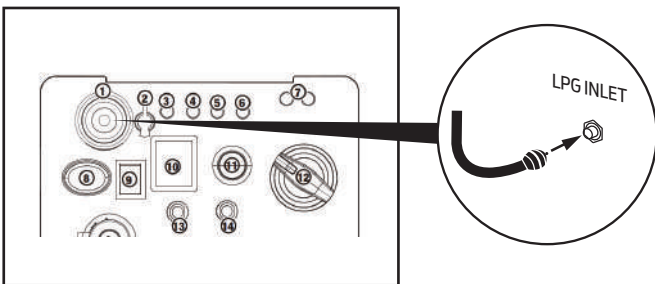

**IMPORTANT:** DO NOT use thread seal tape or any other type of sealant to seal the LPG hose connection.

5. Tighten the LPG hose connector with an adjustable wrench until it is snug. DO NOT overtighten.

6. Remove the safety plug or cap from the propane tank valve and attach the other end of the hose to the LPG connector on the tank. Hand-tighten.

7. Turn the propane tank valve to the fully open position. Check all connections for leaks by wetting the fittings with a solution of soap and water. Bubbles which appear or bubbles which grow indicate that a leak exists. If a leak exists at a fitting, turn the propane tank valve to the fully closed position and tighten the fitting. Open the propane tank valve and recheck the fitting with the soap and water solution. If the leak continues or if the leak is not at a fitting then DO NOT use the generator and contact an authorized Pulsar service center.

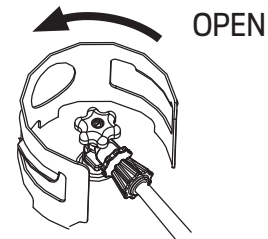

## Connecting the Battery

1. On the left side of the generator, loosen the screws and remove the cover.

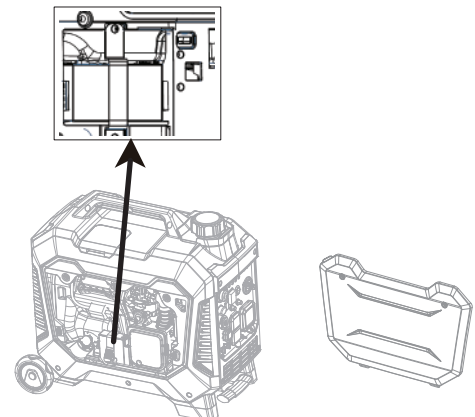

2. A quick connect battery plug is pre-installed on the battery and the generator, connect both together as shown.

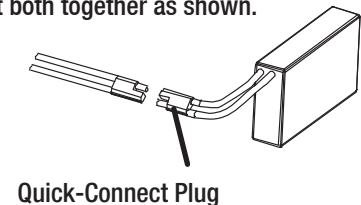

**Note:** Transportation laws require this lithium battery to be shipped in a low state of charge.

It may be necessary to use the recoil (rope) starter when starting the generator for the first time. When running, the generator will automatically recharge the battery.

Pulsar recommends running the generator continuously for the first hour. This will accomplish the engine break in, and it will fully charge the battery.

# Preparation

## Grounding The Generator

Attach grounding wire (if required by code)

- Ground the generator by connecting a suitable grounding cable to the grounding stud on the panel and tightening the nut.
- Connect the other end to a copper or brass grounding rod that's driven into the earth.

A generally acceptable grounding wire is a No. 12 AWG (American Wire Gauge) stranded copper wire.

Grounding codes vary by location. Please contact a local electrician to check the grounding regulations for your area.



Failure to properly ground the generator can result in electrocution.



# Operation

## Generator Location

### ⚠️ WARNING

NEVER operate the generator inside any building, garage, basement, crawlspace, shed, or enclosure, including the generator compartment of a recreational vehicle.

NEVER operate or start the generator in the back of an SUV, camper, trailer, truck bed (regular sides, flat or other configuration), under staircases, stairwells, next to walls or buildings, or in any other location that will not allow for adequate cooling of the generator or for the proper exit of the exhaust flow.

DO NOT operate or store the generator in wet weather conditions such as rain or snow. Using a generator in wet conditions could result in serious injury or death due to electrocution.

Generators must have a minimum of 5 feet (1.5 m) of clearance from all combustible material.

Generators must also have a minimum of 5 feet (1.5 m) of airflow clearance on all sides to allow for adequate cooling, maintenance, and service.

Always place the generator in a well-ventilated area. NEVER place the generator near air intake vents or where exhaust fumes could be drawn into occupied or confined spaces.

Always carefully consider wind and air currents when positioning the generator.

Always allow generators to properly cool before transport or for storage purposes.

Failure to follow proper safety precautions may result in personal injury, damage to the generator, and void the manufacturer's warranty.

### ⚠️ WARNING

During operation, the muffler and exhaust fumes will become hot. If there is inadequate cooling space or if the generator is blocked or enclosed, temperatures can rise quickly and may lead to a fire.

## Starting The Generator

1. Make sure the generator is on a solid, flat, level surface.
2. Disconnect all electrical loads from the generator. Never start or stop the generator with electrical devices attached. Turn the fuel switch to desired fuel source. When the switch is in the gas position, the generator is ready to start with gasoline. When the switch is in the LPG position, the generator is ready to start with propane.

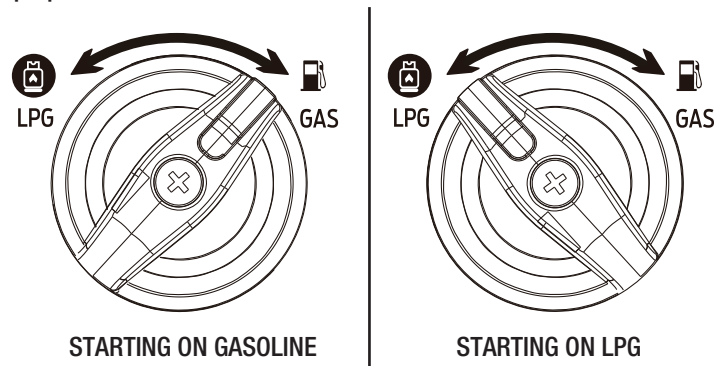

### 3. Turn OFF ECO Switch

The Economy Switch is located on the control panel. Flip the Economy Switch down to disable low idle when starting the generator.

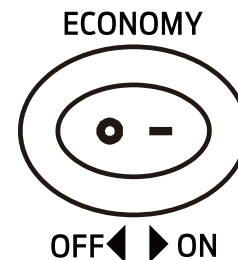

### 4. Turn ON Battery Switch

Press the Battery Switch up to the "ON" position to start the generator.

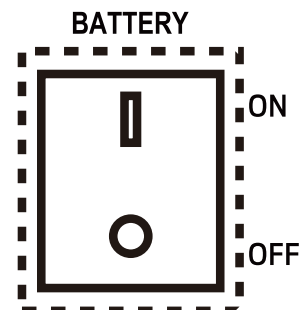

# Operation

## 5. For Recoil Start

**Recoil Start:** Firmly grasp and pull the recoil handle slowly until you feel resistance, let it retract then pull swiftly. If it fails to start successfully, wait for 3 seconds then repeat this step.

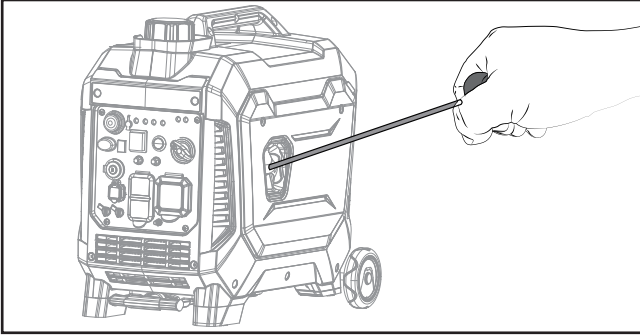

**Engine Start/Stop:** Press the start button once, the engine will attempt to start twice automatically. If it fails to start successfully, press the start button again.

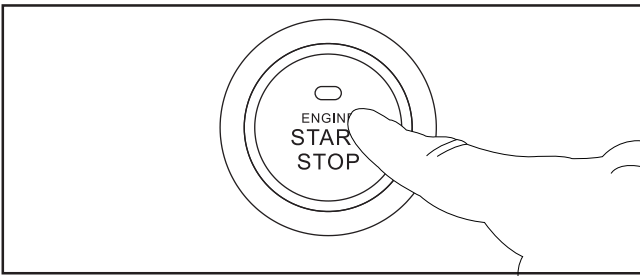

**Remote Start:** Push and hold the ON button on the remote start key fob for one second.

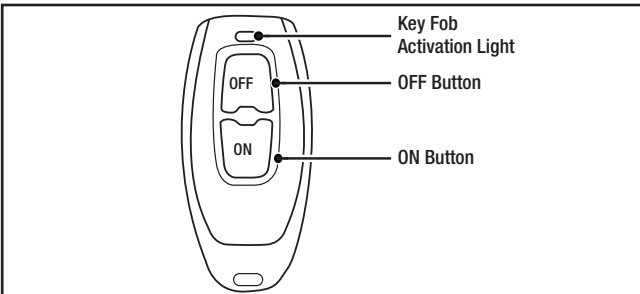

## 6. Plug in devices

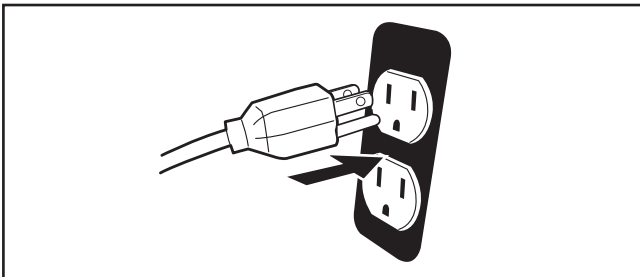

## **! DANGER**

Fire and explosion hazard. Always turn the propane tank valve to the fully closed position if not running the generator on propane.

## **! WARNING**

When using the generator with propane, make sure there is no possible ignition source close to the generator.

## Gasoline To LPG

**IMPORTANT:** Load capacity is reduced when running on LPG. Make sure the generator can supply enough (running) and surge (starting) watts for the devices you are powering before switching to LPG.

1. Turn the LPG tank valve to the fully open position.
2. Turn the fuel selector switch to LPG operation.

## LPG To Gasoline

1. Turn the fuel selector switch to gasoline operation.
2. Turn the LPG tank valve to the fully closed position.

**NOTE:** When switching to LPG operation the engine may run rough for a few seconds while it purges gasoline from the carburetor.

If the engine stops when switching fuel sources, disconnect all loads then restart the unit on the fuel source of choice.

## Parallel Operation

The parallel connection ports allow you to connect two compatible generators to increase the total available electrical power. Follow the instructions included with your parallel connection kit for proper installation and operation.

## Overload Indicator

**Note:** The OVERLOAD light may turn on for a few seconds as a large device starts. This is normal for loads approaching the capacity of this generator.

1. The total combined load through the outlets on the generator must not exceed the running power of the unit.

# Operation

2. If the OVERLOAD light turns on and the generator stops producing power, it has been overloaded.
3. Turn off and disconnect all electrical devices and stop the engine. Compare device requirements to generator rating and reduce the total wattage of connected devices if necessary. Move away anything that may be limiting ventilation..
4. Check if any circuit breakers have tripped and make sure that ALL circuit breakers are reset before starting the generator again.
5. Restart the engine and reconnect devices while being careful to not overload the generator.

## Low Oil Indicator

1. If the engine oil level is too low, the LOW OIL light turns on, the engine will automatically shut off.
2. The engine cannot be restarted until the proper amount of oil has been added.

## NOTICE

Do not run the engine with too little oil. Engine will shut off if engine oil level is too low.

## Economy Switch

1. Turn the economy switch ON to limit noise and fuel consumption for lighter generator loads.
2. Switch low idle OFF to operate engine at full speed when:
  - Starting the generator
  - A heavy load is applied

## Stop The Engine

1. Turn off and unplug all connected electrical loads. Never start or stop the generator with electrical devices plugged in or turned on.

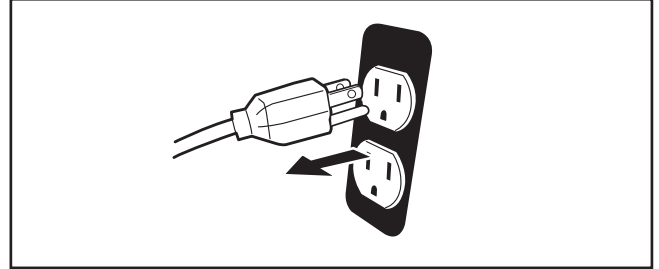

2. Press and hold the START/STOP button for 1-3 seconds to stop the engine.
3. Press the remote start key OFF button for 1-3 seconds to stop the engine.

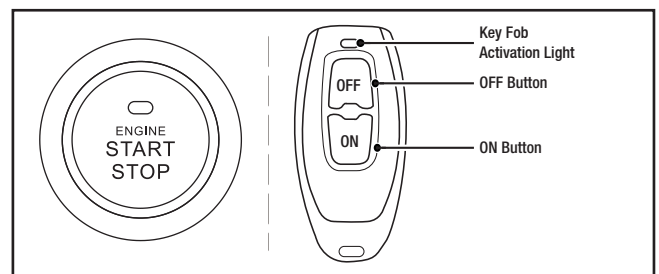

4. Turn OFF Battery Switch.

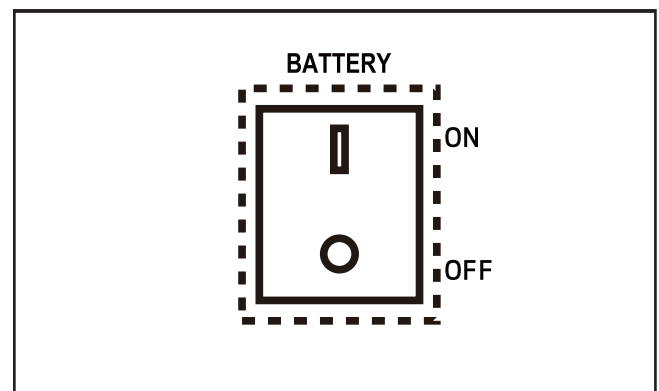

# Operation

## Generator Capacity

### NOTICE

Do not overload the generator's capacity. Exceeding your generator's wattage capacity can damage the generator and/or electrical devices connected to it.

Make sure the generator can supply enough continuous (running) and surge (starting) watts for the devices you will power at the same time.

The total power requirements (Volts x Amps=Watts) of all devices connected must be considered. Appliance and power tool manufacturers usually list rating information near the model or serial number. To determine power requirements:

1. Select the devices you will power at the same time.
2. Total the continuous (running) watts of these devices. This is the amount of power the generator must produce to keep the items running. See the wattage reference chart on the next page.
3. Estimate how many surge (starting) watts you will need. Surge wattage is the short burst of power needed to start electric motor-driven tools or appliances such as a circular saw or refrigerator. Not all motors start at the same time, total surge watts can be estimated by adding only the item(s) with the highest additional surge watts to the total rated watts from step 2.

Example:

Tool or Appliance	Running Watts*	Starting Watts*
RV Air Conditioner (13,000 BTU)	1100	1800
TV (Flat Screen)	150	150
RV Refrigerator	180	600
Radio	50	50
Light (75 Watts)	75	75
Coffee Maker	600	600
	2155 Total Running Watts*	3275 Highest Starting Watts*

\*Wattages listed are approximate. Verify actual wattage.

## High Altitude Operation

At high altitude, the standard carburetor air/fuel mixture will be too rich. Performance will decrease, and fuel consumption will increase. A very rich mixture will also foul the spark plug and cause hard starting. Operation at an altitude that differs from that at which this engine was certified, for extended periods of time, may increase emissions. High altitude performance can be improved by specific modifications to the carburetor. If you always operate your generator at altitudes above 5,000 feet (1,500 meters), have your qualified technician perform this carburetor modification. This engine, when operated at high altitude with the carburetor modifications for high altitude use, will again meet each emission standard. Even with carburetor modification, engine power will decrease about 3.5% for each 1,000-foot (300-meter) increase in altitude.

# Maintenance

## WARNING

Turn the generator “OFF”, wait for the engine to cool, and disconnect the spark plug cable before performing any inspection, maintenance, or cleaning procedures.

**EQUIPMENT FAILURE:** Do not use damaged equipment. If abnormal noise, vibration, or excess smoking occurs, have the problem corrected before further use.

Many maintenance procedures, including any not detailed in this manual, will need to be performed by a qualified technician for safety. If you have any doubts about your ability to safely service the equipment or engine, have a qualified technician service the equipment instead.

## Power

### Cleaning, Maintenance, and Lubrication Schedule

**Note:** This maintenance schedule is intended as a general guide. If performance decreases or if equipment operates unusually, have the generator inspected at once. The maintenance needs of generator will differ depending on factors such as duty-cycle, temperature, air quality, fuel quality.

**Note:** The following procedures are in addition to the regular checks and maintenance explained as part of the regular generator.

Procedure	Before Each Use	Monthly or every 8 hr. of use	Every 3 mo. or 50 hr. of use	Every 6 mo. or 100 hr. of use	Yearly or every 300 hr. of use	Every 2 Years
1. Brush off outside of engine 2. Check engine oil level 3. Check air filter	✓					
Change engine oil				✓		
Clean/replace air cleaner			✓			
1. Check and clean spark plug 2. Check and clean spark arrestor				✓		
1. Check/adjust idle speed 2. Check/adjust valve clearance 3. Clean fuel tank, strainer and carburetor 4. Clean carbon build-up from combustion chamber					✓	
Replace fuel line if necessary						✓

# Maintenance

## Checking and Filling Fuel

### **⚠ WARNING**

TO PREVENT SERIOUS INJURY FROM FIRE:  
You must shut off the engine while refueling.

1. Clean the Fuel Cap and the area around it.
2. Unscrew and remove the Fuel Cap.
3. Remove the strainer and discard any dirt and debris, then replace the strainer.

### **NOTICE**

- Do not use gasoline containing more than 10% ethanol (E10).
  - Do not use E85 ethanol. Add a fuel stabilizer (such as Sta-Bil or Pri-G) to the gasoline or the Warranty is VOID.
  - Do not use gasoline that has been stored in a metal fuel container or a dirty fuel container. It can cause particles to enter the carburetor, affecting engine performance or causing damage.
4. Add fuel, if needed.
  5. Replace the Fuel Cap.
  6. Wipe up any spilled fuel and allow excess to evaporate before starting the engine. To prevent FIRE, do not start the engine while the smell of fuel hangs in the air.

## Engine Oil Change

### **⚠ CAUTION**

Oil is very hot during operation and can cause burns. Wait for the engine to cool before changing the oil.

1. Make sure the engine is stopped and is level.
2. On the right side of the generator, loosen the screws and remove the right-side panel.

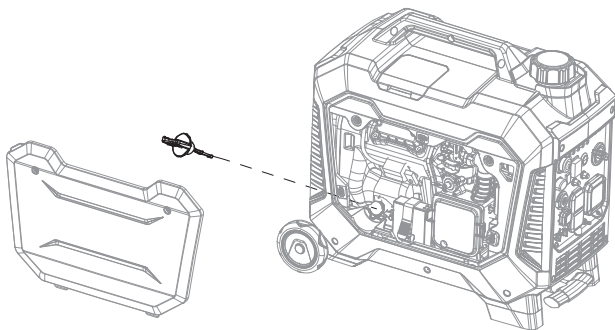

3. Place an oil drain pan under the generator and center it under the oil drain opening.
4. Remove the right access panel and oil plug and set it aside. Tilt the generator so that the oil is discharged from the oil inlet into an approved container.
5. Clean the top of the oil fill and the area around it.
6. Add the appropriate type of oil until the oil level is at the proper level. SAE 10w-30 oil is recommended for general use.

### **NOTICE**

Note: Make sure the generator is level when adding oil to prevent overfilling which could cause engine damage.

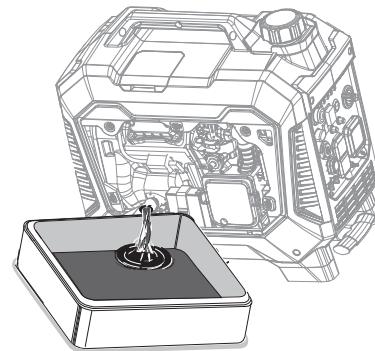

7. Check engine oil level daily and add as needed. Remove and clean the dipstick. Reinsert the dipstick but do not screw it back in. Remove the dipstick and verify the oil is at the correct level.
8. When the engine oil is at the correct level, reinstall the dipstick and screw it down until it is sealed. Then reinstall the right-side panel.

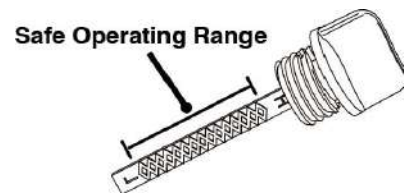

### **NOTICE**

Do not attempt to run the generator with too little oil. The engine will not start with low or no engine oil.

# Maintenance

## Air Filter Maintenance

1. Loosen the screw and remove the left panel to access the air filter.

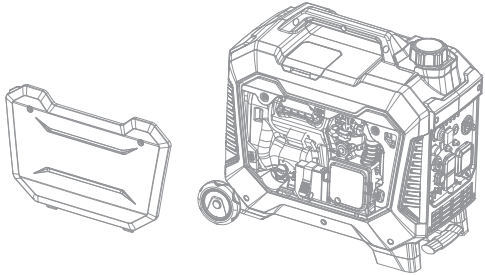

2. Remove Air Filter Cover- see figure below.
3. Remove the air filter element.

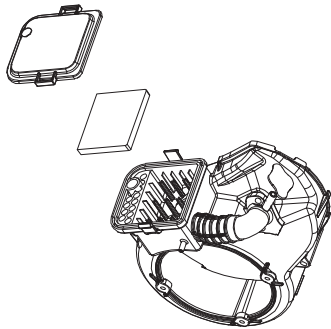

4. Wash the foam air filter element in hot, soapy water, squeezing the solution through the foam until it is clean, rinse the air filter element with clear water and dry it thoroughly before reinstallation.

**NOTE:** Avoid contact with engine oil. Wear protective clothing and safety glasses. Wash all exposed skin with soap and water.

## Spark Arrestor Maintenance



**TO PREVENT SERIOUS INJURY AND FIRE:** Operate only with proper spark arrestor installed

1. Allow the generator to cool completely.
2. Remove the screws from the back of the generator.
3. Remove the clamp and spark arrestor.
4. Clean the Spark Arrestor using a wire brush.
5. Replace the arrestor if damaged.



**TO PREVENT ACCIDENTAL BRUSH FIRE,** secure spark arrestor back in place immediately after cleaning and before further operation.

## Spark Plug Maintenance

1. Remove the spark plug access cover

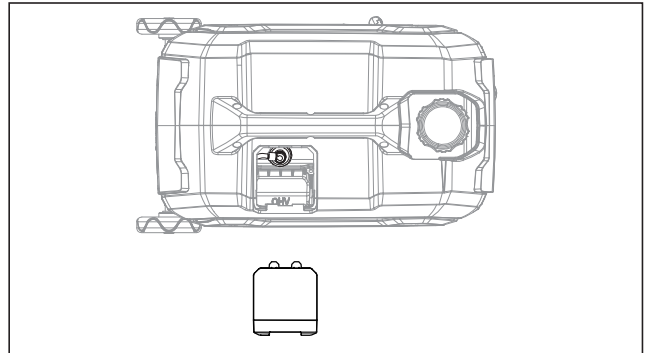

2. Disconnect Spark Plug boot from the end of plug. Clean out debris from around Spark Plug.

3. Using the Spark Plug Wrench, remove the Spark Plug.

4. Inspect the Spark Plug: If the electrode is oily, clean it using a clean, dry rag. If the electrode has deposits on it, clean it with a brass wire brush. If the white insulator is cracked or chipped, replace the spark plug.

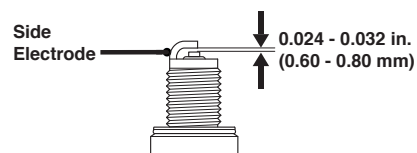

**Spark plug gap:** 0.024 – 0.032 in. (0.60 – 0.80 mm)



# Maintenance

## NOTICE

Use only BPR6ES (NGK) type spark plug or equivalent. Using an incorrect spark plug may damage the engine.

- When installing a new spark plug, adjust the electrode gap to the specification on the Specifications Chart. Do not pry against the center electrode, the spark plug can be damaged.
- Apply anti-seize material to Spark Plug threads. Install the new spark plug or the cleaned spark plug into the engine.

- Hand-tighten until the gasket contacts the cylinder head, then tighten about 3/4 turn more.

## NOTICE

Tighten the Spark Plug properly. If loose, the Spark Plug will cause the engine to overheat. If overtightened, the threads in the engine block will get damaged.

- Re-install the Spark Plug Access Cover.

## Storage

When the generator is to remain idle for longer than 20 days, prepare the engine for storage as follows:

### 1. CLEANING:

Wait for the engine to cool, open both side access panels and blow (or vacuum) any dirt or debris.

## NOTICE

Do not clean using water. The water will gradually enter the engine and cause damage.

### 2. Fuel:

**Gasoline Treatment/Draining the Fuel Tank** To protect the fuel tank during storage, fill the tank with fresh gasoline that has been treated with a fuel stabilizer additive (such as Sta-Bil, or Pri-G).

Follow fuel stabilizer manufacturer's recommendations for use.

## WARNING

Fill the fuel tank in a well-ventilated area away from ignition sources. If the engine is hot from use and wait for it to cool before adding fuel. Do not smoke or vape anything.

### 3. Draining the Carburetor for Generator Storage:

- Make sure that the gasoline tank is empty!
- Loosen two screws, then remove the (left/right) side panel to access the carburetor.
- Locate the clear drain tube, which is attached to the carburetor float bowl, remove the free end, and place it in a gasoline approved container.
- Use a small Phillips-type driver to open the drain screw no more than one turn (CCW), gasoline will drain from the float bowl, collect it in a gasoline approved container.
- Close the drain screw (CW), replace the drain tube, and side panel, then dispose of the old gasoline per local regulations.

## WARNING

To prevent serious injury and fire, move the fuel selector to LPG to shut off gasoline supply before draining the carburetor.

### 4. Extended storage:

- Change engine oil.
- Clean out the area around the spark plug. Remove the spark plug and pour one tablespoon of engine oil into the cylinder through the spark plug hole.
- Replace spark plug, but leave spark plug cap disconnected.
- Pull Starter Handle to distribute oil in the cylinder. Stop after one or two revolutions when you feel the piston start the compression stroke (when you start to feel resistance).

### 5. STORAGE AREA:

Cover and store in a dry, level, well-ventilated area out of reach of children. The storage area should also be away from ignition sources, such as water heaters, clothes dryers, and furnaces.

## NOTICE

During extended storage periods, the engine should be started every 3 months and allowed to run for 15-20 minutes.

### 6. AFTER STORAGE:

Untreated gasoline will deteriorate quickly. Drain the fuel tank and change to fresh fuel if untreated gasoline has been sitting for a month, if treated gasoline has been stored beyond the fuel stabilizer's recommended time, or if the engine does not start.

# Troubleshooting

Problem	Cause	Solution
Engine is running, but AC output is not available	<ol style="list-style-type: none"> <li>1. Open circuit breaker</li> <li>2. Poor connection</li> <li>3. Defective cord set</li> <li>4. Connected device is faulty</li> <li>5. Fault in generator</li> </ol>	<ol style="list-style-type: none"> <li>1. Reset circuit breaker</li> <li>2. Check and repair</li> <li>3. Check and repair</li> <li>4. Connect a device that is working properly</li> <li>5. Contact service department</li> </ol>
Engine runs well without load but bogs down when loads are connected	<ol style="list-style-type: none"> <li>1. Short circuit in connected device</li> <li>2. Generator is overloaded LED light</li> <li>3. Clogged fuel filter</li> <li>4. Engine speed is too slow</li> <li>5. Short circuit in generator</li> </ol>	<ol style="list-style-type: none"> <li>1. Disconnect device</li> <li>2. See pg 17 "Overload Indicator"</li> <li>3. Contact service to replace fuel filter</li> <li>4. Contact service department</li> <li>5. Contact service department</li> </ol>
Engine will not start, shuts down during operation, or starts and runs rough.	<ol style="list-style-type: none"> <li>1. ON/OFF switch set to "OFF"</li> <li>2. Dirty Air filter</li> <li>3. Clogged fuel filter</li> <li>4. Stale fuel</li> <li>5. Spark plug wire disconnected from spark plug</li> <li>6. Bad spark plug</li> <li>7. Water in fuel</li> <li>8. Low oil level (<b>Low oil LED light</b>)</li> <li>9. Intake valve stuck open or close</li> <li>10. Loss of engine compression</li> <li>11. Engine has flooded</li> <li>12. CO Sensor indicator light turn red</li> <li>13. CO Sensor indicator light turns yellow</li> </ol>	<ol style="list-style-type: none"> <li>1. Turn switch to "ON"</li> <li>2. Replace Air filter</li> <li>3. Clean or replace fuel filter</li> <li>4. Replace fuel</li> <li>5. Reconnect spark plug wire</li> <li>6. Replace spark plug</li> <li>7. Drain fuel tank and replace fuel</li> <li>8. Add oil</li> <li>9. Contact service department</li> <li>10. Contact service department</li> <li>11. Contact service department</li> <li>12. Move the generator to an open outdoor area</li> <li>13. Contact service department</li> </ol>
Engine lacks power	<ol style="list-style-type: none"> <li>1. Generator is overloaded</li> <li>2. Clogged in-line filter</li> <li>3. Dirty air filter</li> <li>4. Engine needs servicing</li> </ol>	<ol style="list-style-type: none"> <li>1. See pg. 17 "Overload Indicator"</li> <li>2. Contact service to replace in-line filter</li> <li>3. Replace Air filter</li> <li>4. Contact service department</li> </ol>
Engine "hunts" or falters	<ol style="list-style-type: none"> <li>1. Clogged in-line filter</li> <li>2. Carburetor is running too rich or too lean</li> </ol>	<ol style="list-style-type: none"> <li>1. Contact service to replace in-line filter</li> <li>2. Contact service department</li> </ol>

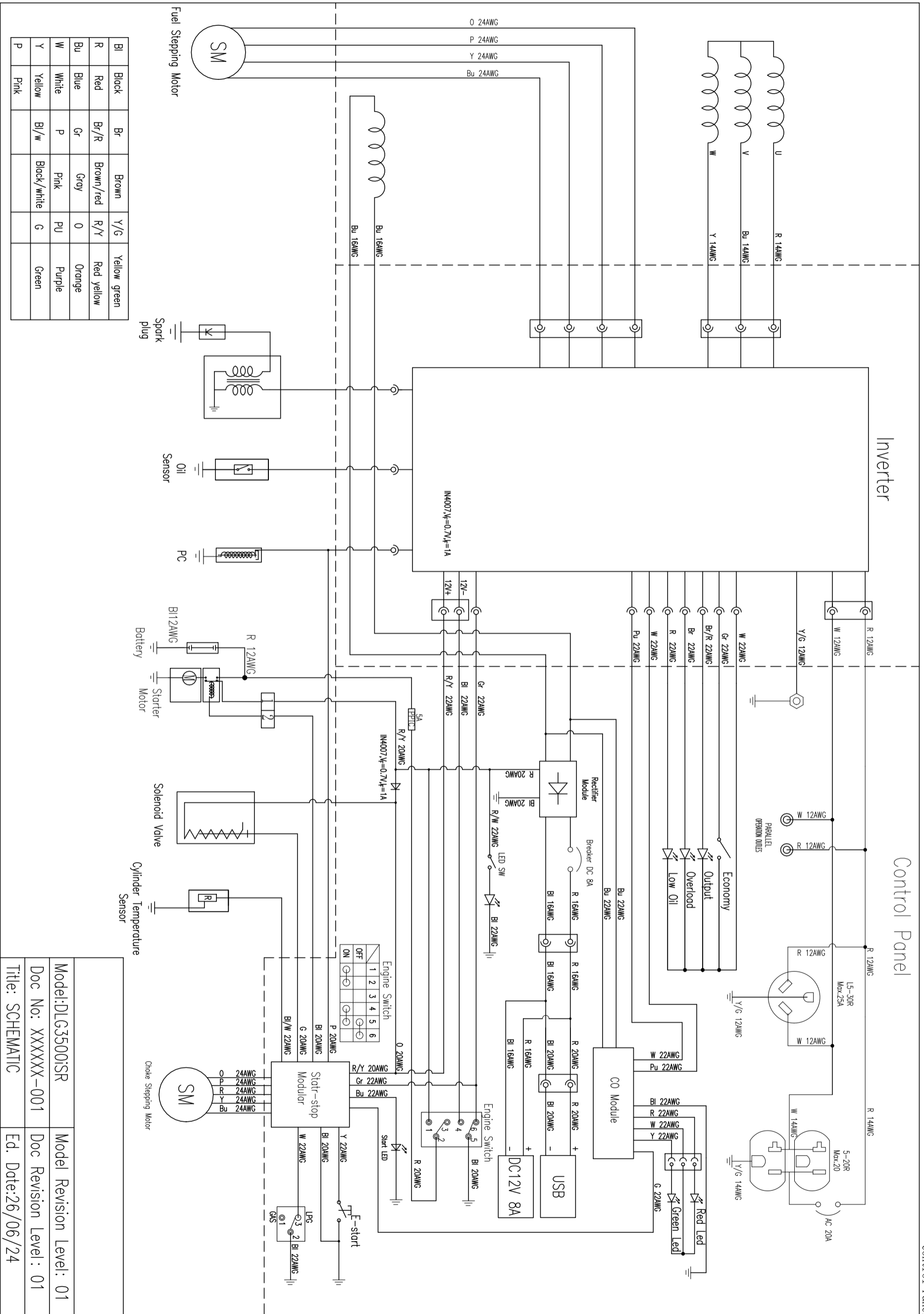

BI	Black	Br	Brown	Y/G	Yellow green
R	Red	Br/R	Brown/red	R/Y	Red yellow
Bu	Blue	Gr	Grey	0	Orange
W	White	P	Pink	PU	Purple
Y	Yellow	Bl/w	Black/white	G	Green
P	Pink				

Model:DLG3500:SR	Model Revision Level: 01
Doc No: XXXXXX-001	Doc Revision Level: 01
Title: SCHEMATIC	Ed. Date:26/06/24