

Model No.: PG13000BRCO

Generator OPERATOR'S MANUAL

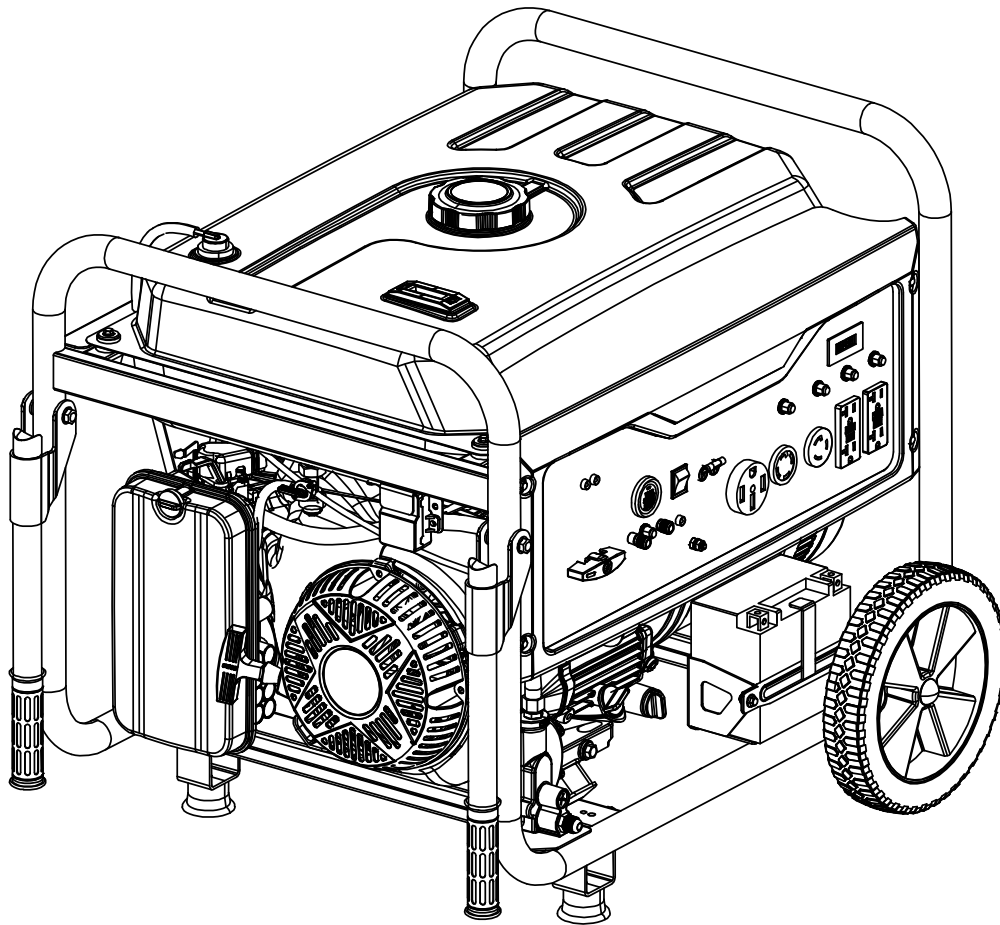

WARNING: This product can expose you to chemicals including Lead, which is known to the state of California to cause cancer and birth defects or other reproductive harm. For more information, visit www.P65warnings.ca.gov.



DO NOT RETURN TO STORE!
HAVE QUESTIONS OR NEED SERVICE?



866-591-8921



support@pulsar-products.com

support@pulsar-products.com

TABLE OF CONTENTS

Introduction	3
Product Specifications	3
Parts Ordering / Customer Service	3
Safety Rules	4
Safety Symbols	4
Safety Instructions	4
Features	7
Assembly	9
Unpacking.....	9
Packing List	9
Attaching Wheels	10
Installing support leg	10
Installing the handles	11
Attaching battery cable	11
Adding Oil/Checking engine oil	12
Adding Fuel.	13
Connecting Generator to a building electrical system.....	13
Operation	14
Grounding the Generator	14
How to Start Engine.	14
How to Stop Engine.	15
Receptacles and Extension Cords.....	15
Do not Overload Generator.....	16
Wattage Reference Guide.	17
Cold Weather Operation.	18
Maintenance	19
Maintenance Schedule	19
Changing Oil	20
Engine Maintenance	21
How to Store	23
Troubleshooting	24
CO Sensor	25
Diagrams	26

INTRODUCTION

Thank you for purchasing this superior quality portable generator from Pulsar Products Inc. When operating and maintaining this product as instructed in this manual, your generator will give you many years of reliable service.

Product Specifications:

This generator is an engine-driven, revolving field, alternating current (AC) portable generator. It is designed to supply electrical power to operate tools, appliances, camping equipment, lighting, or serve as a backup power source during power outages.

AC Output		GAS	LPG
	Rated Wattage	10200W (10.2kW)	9200W (9.2kW)
	Rated Voltage	120V/240V	120V/240V
	Rated Frequency	60Hz	60Hz
	Rated Ampere	85A / 42.5A	76.6A / 38.3A
	Rated Output	10.2kVA	9.2kVA
	Maximum Output	13kVA	11.5kVA
Engine	500cc OHV, 4 Stroke, Air Cooled		
Engine Oil	10W30 - 40.6oz (1.2L)		
Fuel Tank	9.5 Gal (36L) Unleaded Gasoline		

The emissions control system for this generator is compliant with all standards set by the US EPA.

How to contact us:

To order parts, receive warranty assistance, or other services inquiries, you can contact us via our website at support@pulsar-products.com or write to us at:

PULSAR PRODUCTS, INC
5721 E. SANTA ANA ST.
ONTARIO, CA 91761
866-591-8921

Save your original sales receipt and record the following information below for service or warranty assistance.

Date of Purchase:	
Model Number:	
Item Number:	
Serial Number:	



SAVE THIS MANUAL FOR FUTURE REFERENCE

This manual contains important information regarding safety, operation, and maintenance.

SAFETY RULES

Safety Symbols



Indicates a potentially hazardous situation which could result in serious injury or death if not avoided.



Indicates a potentially hazardous situation which could result in damage to equipment or property.



Toxic Fumes



Risk of fire



Risk of explosion



Risk of electric shock



Hot surface



Lifting hazard

Safety Instructions

The manufacturer cannot anticipate every possible hazardous circumstance that the user may encounter. Therefore, the warnings in this manual, on tags, and on affixed decals are not all-inclusive. To avoid accidents, the user must understand and follow all manual instructions and use common sense.



Read and understand this manual in its entirety before operating this generator. Improper use of this generator could result in serious injury or death.



Do not operate indoors or in a confined space that prevents dangerous carbon monoxide gas from dissipating.

- Using a generator indoors **CAN KILL YOU IN MINUTES!**
- Carbon monoxide gas is a poisonous, odorless gas that can cause headache, confusion, fatigue, nausea, fainting, sickness, seizures, or death. If you start to experience any of these symptoms, **IMMEDIATELY** get fresh air and seek medical attention.
- Never use indoors, in a covered area, or in a confined space, even if doors and windows are open.
- Install a battery-operated carbon monoxide alarm near bedrooms.
- Keep exhaust from this unit from entering a confined area through windows, doors, vents, or other openings.
- When working in areas where vapors could be inhaled, use a respirator rated for carbon monoxide protection.



Engine exhaust contains chemicals that lead to cause cancer and birth defects.

- Always wash hands after handling generator.



To reduce the risk of serious injury, avoid attempting to lift the generator alone.

SAFETY RULES



WARNING!

Never exceed generator's wattage / amperage capacity. This could damage the generator and / or connected electrical devices.

- Check operating voltage and frequency requirements of all electrical devices prior to plugging them into the generator.



WARNING!

Never start or stop engine with electrical devices plugged in to the receptacles. Failure to do so could damage the generator and / or connected electrical devices.

- Always start the engine and let it stabilize before connecting any electronic devices.
- Disconnect all electronic devices before stopping the engine.



WARNING!

Starter and other moving parts can catch on clothing, jewelry, and hair.

- Do not wear loose clothing or gloves.
- Remove jewelry or anything else that could be caught in moving parts.
- Tie back or wear protective head covering to contain long hair.



WARNING!



Keep engine away from flammable objects and other hazardous materials.

- The fuel and its vapors used to power this unit are highly flammable and could explode resulting in serious injury or death.
- Never fill or drain fuel tank indoors.
- Never overfill fuel tank. If fuel spills, move the unit at least 30 feet away from the spill and wipe up any remaining fuel on the unit before starting the engine.
- Never smoke while operating or fueling this unit.
- Never operate or store this unit near an open flame, heat, or any other ignition source.
- Generator should be far away from buildings or other equipment during operation.
- Keep engine free of grass, leaves, or grease and other flammable debris.
- When adding or draining fuel, unit should be turned off for at least 2 minutes to cool before removing fuel cap. If unit has been running, the fuel cap may be under pressure, remove slowly.
- To keep fuel from spilling, secure unit so it cannot tip while operating or transporting.
- When transporting unit, disconnect the spark plug wire and make sure the fuel tank is empty with the fuel shutoff valve turned to the off position.



WARNING!

Pull cord recoils rapidly and pulls arm towards engine faster than you can let go which could result in injury.

- To avoid recoil, pull starter cord slowly until resistance is felt, then pull rapidly.



WARNING!



Avoid contacting hot areas of this unit.

- Use caution around the muffler, cylinder, and other engine parts as they can be extremely hot.
- Allow hot components to cool before touching.

SAFETY RULES



WARNING!



This generator produces high voltage which could result in burns or electrocution causing serious injury or death.

- Never handle the generator, electrical devices, or any cord while standing in water, while barefoot, or when hands or feet are wet.
- Always keep the generator dry. Never operate generator in rain or under wet conditions.
- Use a ground fault circuit interrupter (GFCI) in a damp or highly conductive area, such as metal decking or steel work.
- Never plug electrical devices into generator having frayed, worn, or bare wires. Never touch bare wires or contact receptacles.
- Never permit a child or unqualified person to operate generator. Always keep children a minimum of 10 feet away from the generator.
- If using the generator for backup power, notify the utility company.
- If connecting generator to a building's electrical system for standby power, you must use a qualified electrician to install a transfer switch. Failure to isolate the generator from the power utility could result in serious injury or death to electric utility workers.



WARNING!



Generator must be properly grounded to prevent electrocution.

- Only operate generator on a level surface.
- If connected to a structure, connect the ground terminal on the frame to an appropriate ground



WARNING!

Never modify this unit in any way or modify governed speed.

- Increasing governed speed is dangerous which can result in personal injury and / or damaged equipment.
- Decreasing governed speed adds an excessive load and can damage equipment.
- Only when operating at the preset governed speed this generator will supply the correct rated frequency and voltage.



WARNING!

Only use this unit as intended or serious injury or death could result.

- Do not bypass any safety device. Moving parts are covered with guards. Make sure all protective covers are in place.
- Never transport or make adjust this unit while it is running.
- Never insert objects through cooling slots.



WARNING!

Never operate this unit if there are any broken or missing parts and only use replacement parts specifically designed for this unit.

- Improper treatment of generator can damage the unit and shorten its life.
- Always repair this unit as specified in this manual. If you have any questions, contact your dealer, or consult a qualified service center.
- Shut generator off if electrical output is missing, unit vibrates excessively or begins to smoke, spark, or emit flames.

PROP 65 WARNING: This product contains chemicals known to the state of California to cause cancer and birth defects or other reproductive harm.

FEATURES

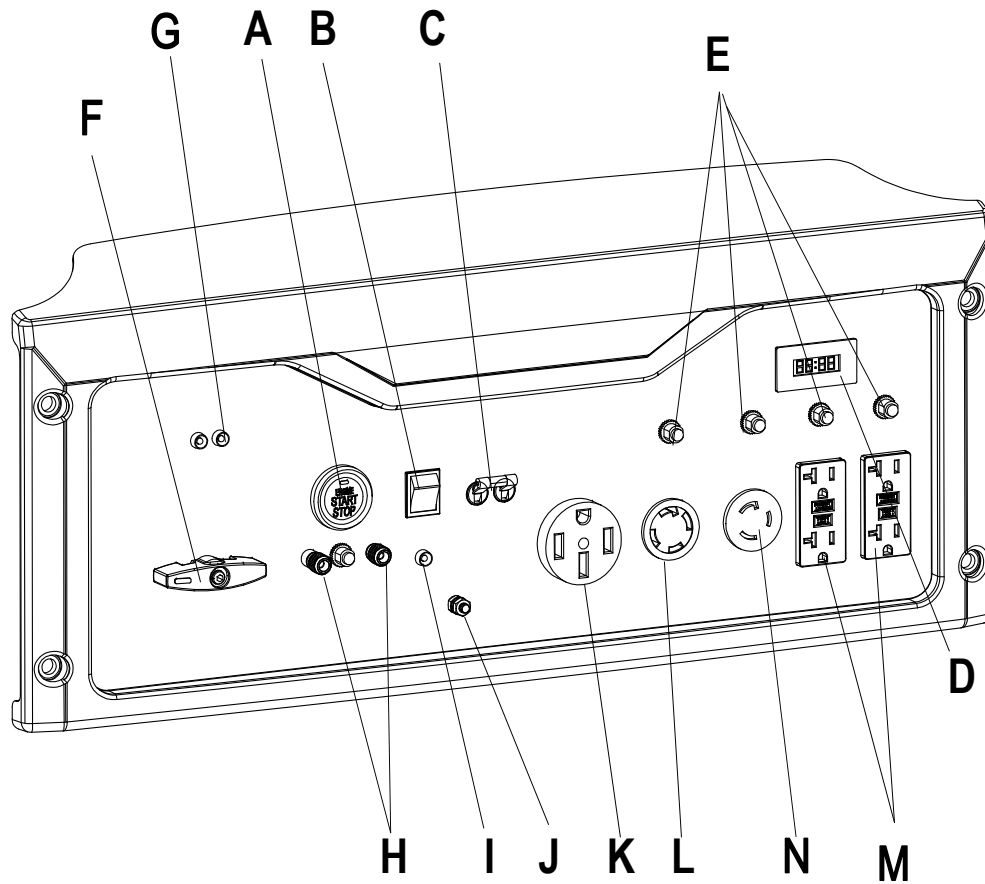

- A. Push Start
- B. ON/OFF Switch
- C. Main Circuit Breaker
- D. Status Display
- E. Circuit Breaker
- F. Fuel Selector Switch
- G. CO Sensor Light

- H. 12 Volt 8.3 Amp Output (For charging batteries only)
- I. Battery Indicator
- J. Ground Terminal
- K. 120V/240V AC, 50 A Outlet (NEMA 14-50R)
- L. 120/240V AC, 30Amp Twist-Lock Outlet (L14-30R)
- M. Four 120V GFCI Outlets (NEMA 5-20R)
- N. 120 AC, 30Amp Twist-Lock Outlet (L5-30R)

FEATURES

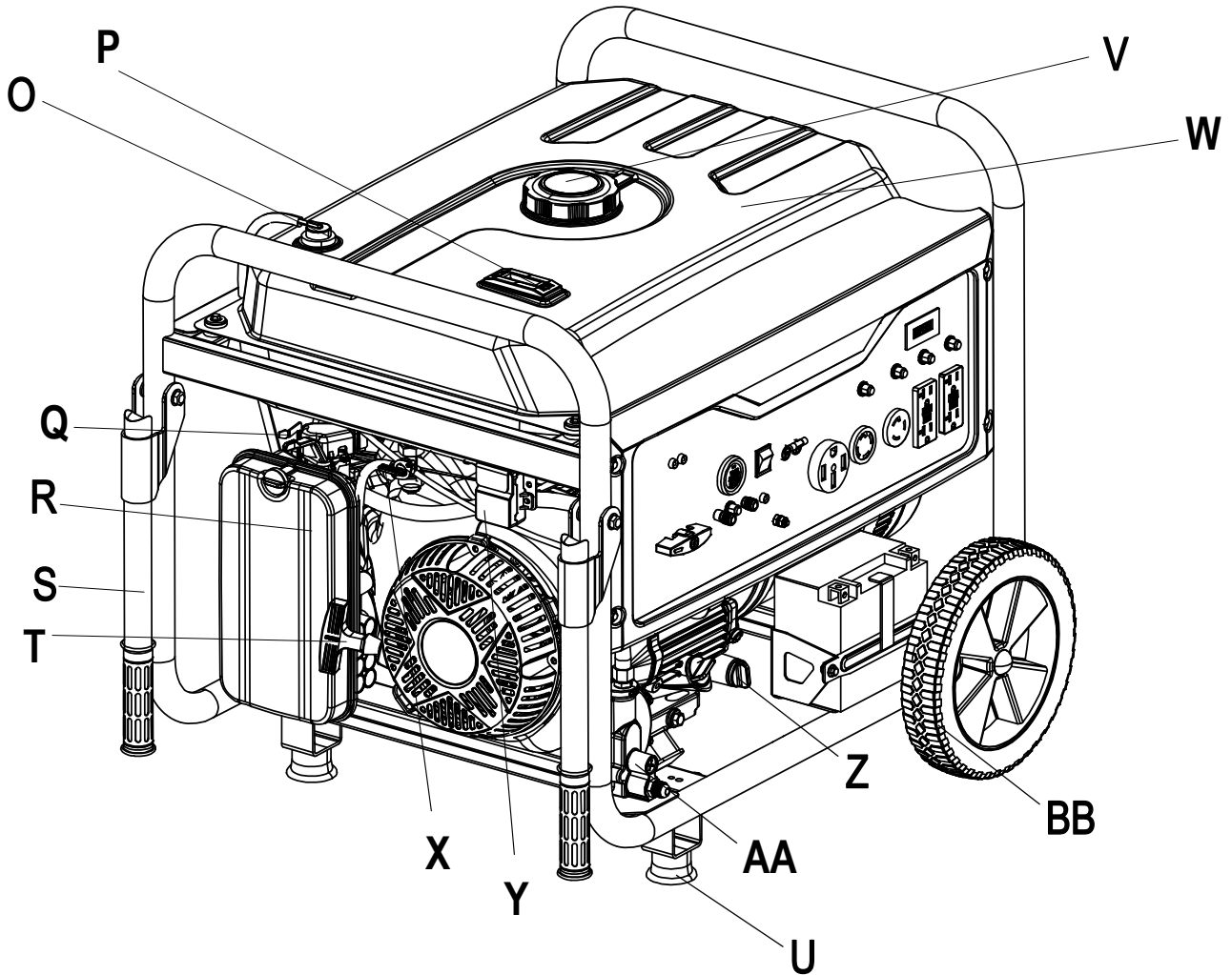

- O. Tank Vapor Valve
- P. Fuel Gauge
- Q. Choke Lever
- R. Air Filter Housing
- S. Handle
- T. Pull Start
- U. Support Feet
- V. Fuel Cap
- W. Gas Tank
- X. Fuel Valve
- Y. CO sensor
- Z. Oil Fill (Dipstick)
- AA. Propane Inlet
- BB. No Flat Wheels

ASSEMBLY

Unpacking

1. Place box on a level surface.
2. Remove all items from box except the generator. Make sure all items listed on the packing list are included and undamaged.
3. Cut-down the sides of the box being careful to avoid touching the generator.
4. Leave generator on box to install wheels.

Packing List

Check all loose parts to the following list. Contact your dealer if any loose parts are not included.

Description	Qty	
Generator	1	
Operator 's Manual	1	
Products Warranty Card	1	
Toolkit	Spark Plug Wrench	1
	Combination Wrench	2
Funnel	1	
Handles	2	
Bushings (Flanged)	4	
Two-stage regulator	1	

Description	Qty
Wheel	2
Axle	2
Hair pin	2
Screw M8x50	2
Washer	2
Supporting Feet	2
Nuts M8	6
Screw M8x16	4
Measuring cap	1

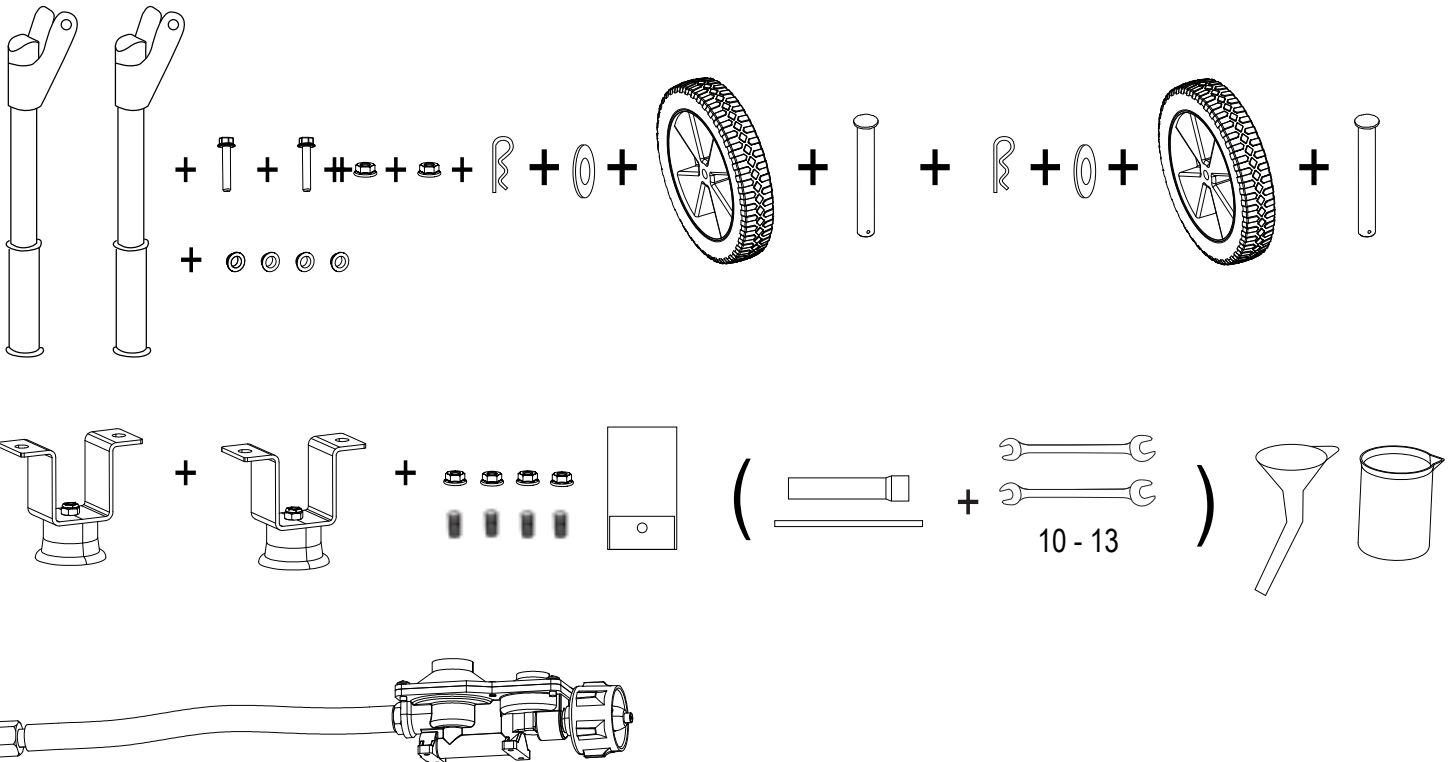

ASSEMBLY

Attaching Wheels (See fig 1)

- Parts needed - 2 wheels, 2 axles, 2 hair pins, and 2 washers.
- Raise or tilt generator so you can slide the wheel axle pin into the wheel, the washer, the wheel mounting hole located on the side of the frame.
- Secure the wheel assembly by inserting a hair pin through hole at the end of the wheel axle and pressing until it locks into place.
- Repeat process on the other side of the generator to install the second wheel.

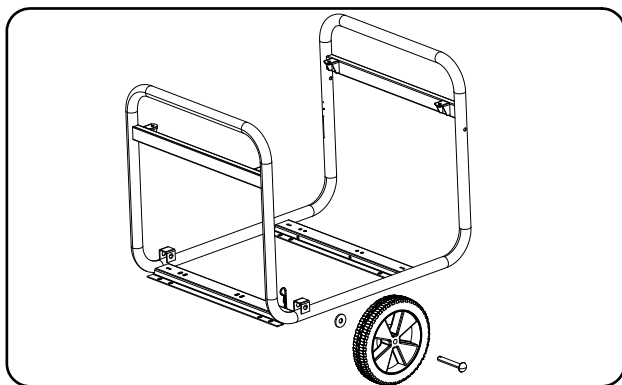

Fig 1

Installing Support Leg (See fig 2)

- Parts needed - Support Leg(2) & 4 nuts & 4 Screw.
- Raise the front end of the generator high enough to gain access to the bottom of the frame. Securely position props underneath to support.
- Line up holes on the support leg bracket to the holes on the front of the generator frame.
- Attach the support leg with the screws and nuts.

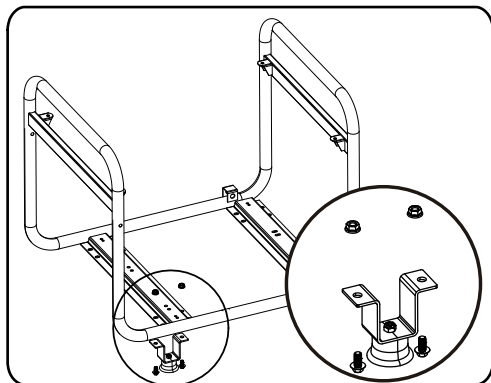

Fig 2

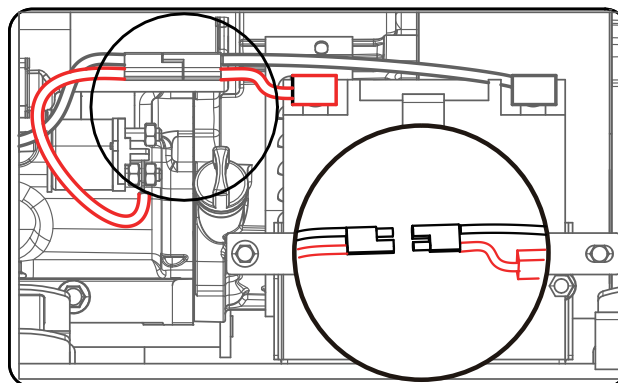

Fig 3

ASSEMBLY

Attaching Battery Cable (See fig 3)

- Locate the pigtail harness already attached to the battery (-) negative post
- Ensure the hardware is tight and the red rubber boot is fitted over the (+) battery connection
- Align the male and female battery cable connectors and firmly fit them together



CAUTION!

Be careful not to short across the terminals when installing. Shorting the terminals together can cause sparks, damage to the battery or generator, or even burns or explosions.

Cover the terminals with the rubber covers

When removing the battery for replacement: Remove the nut and bolt first from the negative (Black) post, then from the positive (Red) post, being careful not to short across the terminals. Always abide by the safety warnings provided with the battery. Remove the battery and dispose of it according to your local and state regulations.



WARNING!

Battery posts, terminals, and accessories contain lead and lead compounds known to cause cancer and reproductive harm.

- Always wash hands after touching battery.

Intalling The Handles (See fig 4)

- Place 2 bushings on handle and slide handle in place with the pre-drilled hole on the generator frame.
- Insert bolt through the handle and frame and tighten with nut.
- Repeat on opposite side.

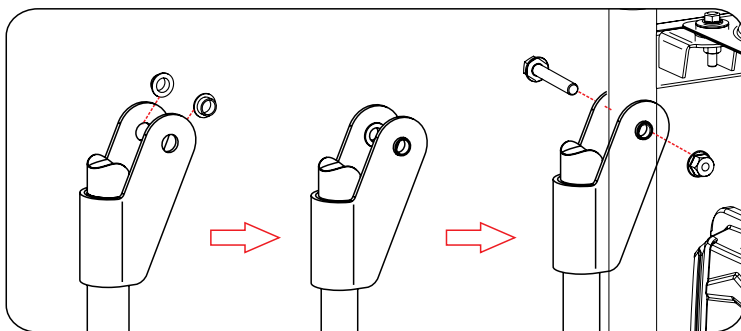

Fig 4

ASSEMBLY

NON-SPILLABLE SEALED BATTERY

This is a ready filled, activated sealed battery. Never remove strip. Refer to owner's manual or instruction sheet for charging procedures.



! DANGER/POISON



SHIELD EYES.
EXPLOSIVE GASES CAN CAUSE BLINDNESS OR INJURY



NO
• SPARKS
• FLAMES
• SMOKING



SULFURIC ACID
CAN CAUSE BLINDNESS OR SEVERE BURNS



FLUSH EYES IMMEDIATELY WITH WATER

GET MEDICAL HELP FAST

WARNING!

- Wear Eye Protection
- Never Reverse Pole Connections
- Never turn the battery upside down
- DO NOT Smoke near the battery
- If electrolyte contact the skin wash the area immediately with clean water
- If you get electrolyte contact with your eye, rinse immediately with clean water and seek medical attention

NOTICE:

- If the Generator is stored for over six months the battery will need to be removed and charged

PROPOSITION 65 WARNING

- Battery posts, terminals, and related accessories contain lead and lead compounds, chemicals known to the State of California to cause cancer and reproductive harm.
- Wash hands after handling.



Antidotes for battery acid

CONTACT	TREATMENT
External	Flush with water.
Internal	Drink large quantities of milk or water, followed by milk of magnesia, vegetable oil or beaten eggs. Get immediate medical attention.
Eyes	Flush with water. Get immediate medical attention.

Adding / Checking Engine Oil (See fig 5)

- Place generator on a level surface.
- Insert a funnel into the crankcase dipstick hole and carefully add 4-Cycle engine oil (SAE10W- 30) to empty crankcase until oil reaches the outer edge of the oil fill hole (crankcase dipstick hole).
- Be sure to replace dipstick before attempting to start the engine.
- To check oil, set generator on a level surface, wipe dipstick clean, then reinsert dipstick without rethreading.

ASSEMBLY

Adding Fuel (See fig 6)

- Set generator outdoors in a well-ventilated area, away from structures and people.
- Slowly remove fuel cap.
- Insert a funnel into the fuel tank and carefully pour gasoline into the tank until fuel level reaches 1 ½ inches below the top of the neck. Be careful not to overfill the tank to allow space for fuel expansion.



CAUTION!

You must add oil before first operating this generator. Always check oil level before each operation.

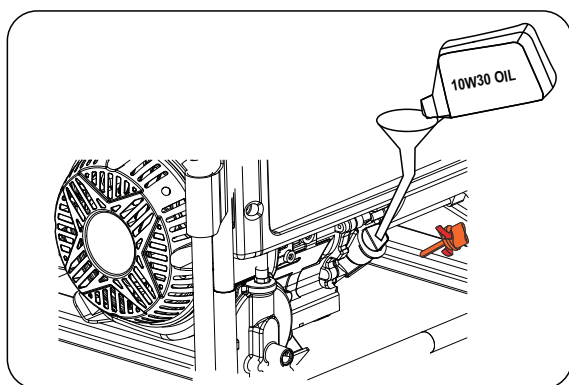

Fig 5

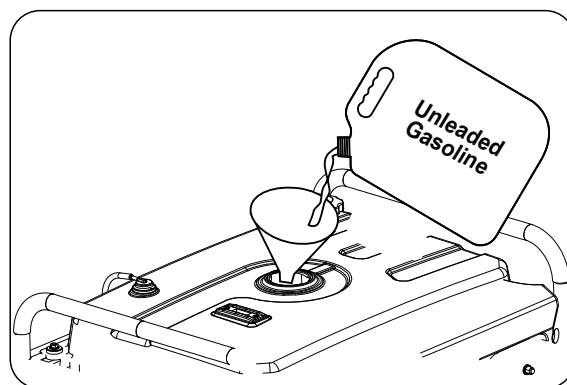

Fig 6

Connecting Generator to a Building Electrical System

- If connecting generator to a building electrical system for standby power, you must use a qualified electrician to install a transfer switch. The power from the generator must be isolated from the utility power source. The connection must comply with all electrical codes and applicable laws.



WARNING!



This generator produces high voltage which could result in burn or electrocution causing serious injury or death.

- Never handle the generator, electrical devices, or any cord while standing in water, while barefoot, or when hands or feet are wet.
- Always keep the generator dry. Never store or operate generator in rain or under wet conditions.
- Use a ground fault circuit interrupter (GFCI) in a damp or highly conductive area, such as metal decking or steel work.
- Never plug electrical devices into generator having frayed, worn, or bare wires. Never touch bare wires or contact receptacles.
- Never permit a child or unqualified person to operate generator. Always keep children a minimum of 10 feet away from the generator.
- If using the generator for backup power, notify the utility company.
- If connecting generator to a building's electrical system for standby power, you must use a qualified electrician to install a transfer switch. Failure to isolate the generator from the power utility could result in serious injury or death to electric utility workers.

OPERATION

Grounding the Generator (See fig 7)

The portable generator is equipped with a terminal for the connection of a ground electrode conductor where a grounding electrode system is required by NEC Article 250.34(A). The equipment grounding conductors of the generator receptacles are bonded to the generator frame. Where the generator supplies power to cord and plug connected equipment, like power tools, the frame of the generator is not required by the NEC to be connected to an earthen ground electrode. The generator neutral conductor is bonded to the generator frame in accordance with NEC Article 250.34(C)

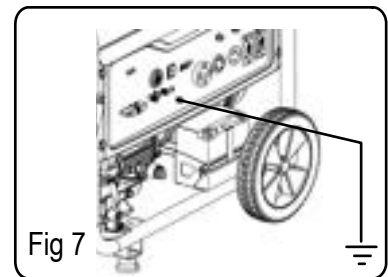

WARNING!



Generator must be properly grounded to prevent electrocution.

•Always connect the nut and ground terminal on the frame to an appropriate ground source.

How to Start Engine (See fig 8-14)

Place generator on a level surface. All electrical loads **MUST** be disconnected from generator.

WHEN USING GASOLINE

- Turn fuel valve to the "ON" position. (See fig 9)
- Turn the fuel selector to "GAS" position (See fig 10)
- Push the battery switch to the "RUN" position.

For Push Button Start: Push and hold the One Push Start Button for no more than 1 second and release. The engine will automatically set the choke and begin the start sequence. If it fails to start successfully, repeat this step. If it fails to start after 5 attempts, refer to the "TROUBLESHOOTING" section on page 24 of the operator's manual (See fig 11)

For Manual Start: Pull the recoil starter grip slowly until resistance is felt, then pull rapidly. (See fig 12)

For Remote Control Start: Push and hold start button for no more than 1 second and release (See fig 13)

WHEN USING LPG

- Connect LPG hose to the the propane tank and to the generator; Open the valve of LPG bottle (See fig8)
- Turn the fuel selector to "LPG" position (See fig 10)

For Push Button Start: Push and hold the One Push Start Button for no more than 1 second and release. The engine will automatically set the choke and begin the start sequence. If it fails to start successfully, repeat this step. If it fails to start after 5 attempts, refer to the "TROUBLESHOOTING" section on page 24 of the operator's manual (See fig 11)

For Manual Start: Pull the recoil starter grip slowly until resistance is felt, then pull rapidly. (See fig 12)

For Remote Control Start: Push and hold start button for no more than 1 second and release (See fig 13)

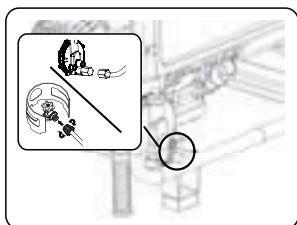

Fig 8

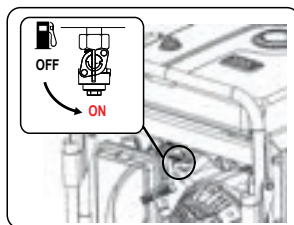

Fig 9

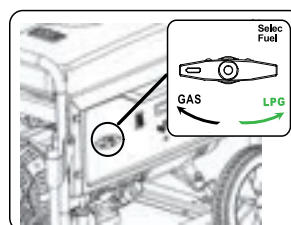

Fig 10

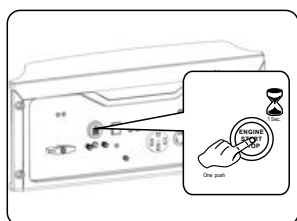

Fig 11 Electric Start

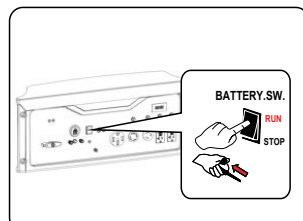

Fig 12 Recoil Start

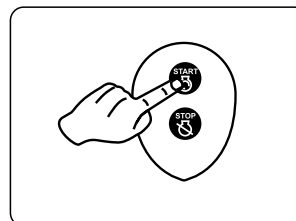

Fig 13

OPERATION



WARNING!

Never start or stop engine with electrical devices plugged in to the receptacles. Failure to heed this warning could damage the generator and / or connected electrical devices.

- Always start the engine and let it stabilize before connecting any electrical devices.
- Disconnect all electrical devices before stopping the engine.



WARNING!

Pull cord recoils rapidly and can pull arm towards engine faster than you can let go could result in injury.

- Pull starter cord slowly until resistance is felt, then pull rapidly.

Battery Charger for Electric Starter

Keep the generator battery fully charged and ready to use to avoid the need to use the recoil starter to start the generator manually.

How to Stop Engine (See fig 14-17)

- All electrical loads **MUST** be disconnected from the generator. Never start or stop the engine with electrical devices plugged in to the receptacles. (See fig 14)

When using gasoline

1. Turn the battery switch to the "STOP" position. (See fig 17)
2. Turn the fuel valve lever back to the OFF position. (See fig 15)

When using LPG

1. Turn the battery switch to the "STOP" position. (See fig 17)
2. Turn off LPG bottle. (See fig 16)

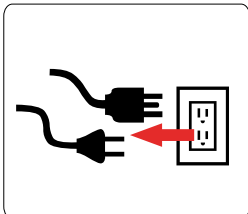

Fig 14

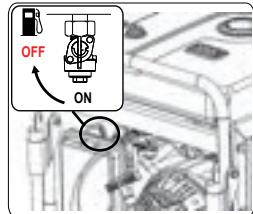

Fig 15

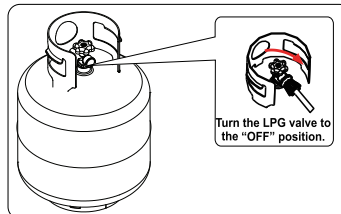

Fig 16

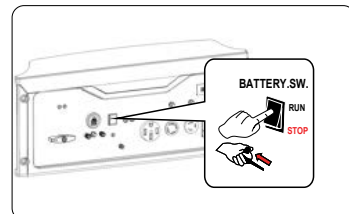

Fig 17

Receptacles and Extension Cords

Only use high quality, well-insulated, grounded extension cords in good condition with generator receptacles. Follow each device manufacturer's power rating recommendation when selecting receptacle and extension cord.

This generator is equipped with the following receptacles:

- Four 120 Volt GFCI duplex receptacles (NEMA 5-20R).
- 120 / 240 Volt AC, 50 Amp receptacle (NEMA L14-50R).
- 120 / 240 Volt AC, 30 Amp twist lock receptacle (NEMA L14-30).
- 120 Volt AC, 30 Amp twist lock receptacle (NEMA L5-30R).
- 12 Volt DC 8.3 Amp Output.

OPERATION



CAUTION!

Do not connect 3-phase loads to generator.



WARNING!

12 Volt 8.3 Amp Output is for charging batteries only!

Extension Cord Selection

Refer to the below table to ensure the extension cord used has the capacity to carry the required load. If the size of the cable is inadequate it can cause a voltage drop and heat buildup, which can damage the electrical device and cord.

Current (Amps)	Load (Watts)		Maximum Cord Length				
	120V	240V	#8 Wire	#10 Wire	#12 Wire	#14 Wire	#16 Wire
2.5	300	600	X	1000 ft.	600 ft.	375 ft.	250 ft.
5	600	1200	X	500 ft.	300 ft.	200 ft.	125 ft.
7.5	900	1800	X	350 ft.	200 ft.	125 ft.	100 ft.
10	1200	2400	X	250 ft.	150 ft.	100 ft.	50 ft.
15	1800	3800	X	150 ft.	100 ft.	65 ft.	X
20	2400	4800	175 ft.	125 ft.	75 ft.	X	X
25	3000	6000	150 ft.	100 ft.	X	X	X
30	3600	7200	125 ft.	65 ft.	X	X	X

Moving the Generator

- Disconnect any electrical devices from generator then switch the generator off.
- Turn fuel valve to the "OFF" position, turn the battery switch to stop.
- Use the handle to tilt generator until it balances on wheels. Roll machine to desired location.
- If the generator must be carried, fold handle to the down position. Never lift or carry generator by its handle.



CAUTION!

This product is heavy and requires several people to lift. Lift and lower with your legs by bending the knees, not your back, to avoid injury.

Don't Overload Generator

Make sure you can supply enough rated watts and surge watts for all electrical loads connected to the generator. Rated watts refer to the power a generator must supply to keep a device running. Surge watts refer to the power a generator must supply to start an electrical device. This power surge for starting a device usually lasts between 2-3 seconds but this additional output must be considered when selecting the electrical devices, you plan to attach to the generator. To prevent overloading the generator, take the following steps:

OPERATION

Operating voltage and frequency requirement of all electrical equipment should be checked prior to plugging them into this generator. Damage may result if the equipment is not designed to operate within a +/- 10% voltage variation, and +/- 3 Hz frequency variation from the generator name plate ratings. To reduce the risk of damage, always have an additional load plugged into the generator if solid-state equipment (such as television set) is used. A power line conditioner is recommended for some solid-state applications.

Wattage Reference Guide

(Wattages listed are just approximations. Check electronic device for actual wattage)

Essentials	Rated Watts	Surge Watts
75W Light Bulbs	75 each	75 each
18 CU Ft Refrigerator / Freezer	800	2200
Furnace Fan (½ HP)	800	2350
Sump Pump (½ HP)	1000	2000
Water Pump (½ HP)	1000	3000
Heating/Cooling		
Dehumidifier	650	800
Table Fan	200	300
Window AC (10k BTU)	1200	3600
Central Air (4 ton)	1500	6000
Electric Blanket	400	400
Space Heater	1800	1800
Kitchen		
Blender	300	900
Toaster (2 slice)	1000	1000
Coffee Maker	1500	1500
Electric Range (1 element)	1500	1500
Dishwasher	1500	2000
Electric Oven	3500	3500
Electric Water Heater	4000	4000
Laundry Room		
Iron	1200	1200
Washing Machine	1150	2400
Gas Clothes Dryer	700	1500
Electric Clothes Dryer	5400	6750

Bathroom	Rated Watts	Surge Watts
Hair Dryer	1250	1250
Curling Iron	1000	1000
Family Room		
X-Box or Play Station	40	40
AM/FM Radio	100	100
VCR	100	100
TV or Monitor (40")	200	200
Home Office		
Fax Machine	65	65
Personal Computer (17" Monitor)	800	800
Laser Printer	250	950
Copy Machine	700	800
Power Tools		
1000W Quartz Halogen Work Light	1000	1000
Airless Sprayer (½ HP)	600	800
Reciprocating Saw	750	950
Circular Saw (7 ¼")	1400	2300
Miter Saw (10")	800	1200
Table/Radial Arm Saw	1000	2000
Electric Drill (½ HP, 5.4 Amps)	600	900
Hammer Drill	700	1000
Air Compressor	1600	4500
Other		
Home Security System	500	500
Garage Door Opener (½ HP)	750	750



WARNING!

Never exceed generator's wattage/ampere capacity. This could damage the generator and / or connected electrical devices.

- Check operating voltage and frequency requirements of all electrical devices prior to plugging in to the generator.

OPERATION

Hour Meter (See Fig 19)

Use this meter along with the manual to determine when and what type of service on the unit is needed. The display will show the word "LUBE" at the first 25 hours of operation and again at every 100 hours of operation after.

Power Management

- Start engine without anything connected to generator.
- When engine has stabilized, plug in and turn on first load. It is strongly recommended to plug in devices with the largest load first and the smallest load last to help prevent overloading the generator.
- Allow generator output to stabilize (engine and attached devices run evenly) before plugging in the next load.

Charging a 12 Volt Battery (See Fig 20)

This generator can be used to charge a 12 volt automotive or storage battery by taking the following steps:

- Inspect fluid level of the battery cells.
- Add ONLY distilled water to any cell where fluid level is low. Never add tap water.
- Use a wire brush to clean battery terminals if corroded.
- Connect the Battery Charging Cable to the 12 Volt DC posts.
- Connect the red cable clamp to the positive (+) battery terminal.
- Connect the black cable clamp to the negative (-) battery terminal.
- Start generator engine. Let engine run while battery charges.
- Battery is considered fully charged when the gravity of its fluid is 1.260 or higher when measured by a hydrometer. Its static voltage is > 12.7 vdc.

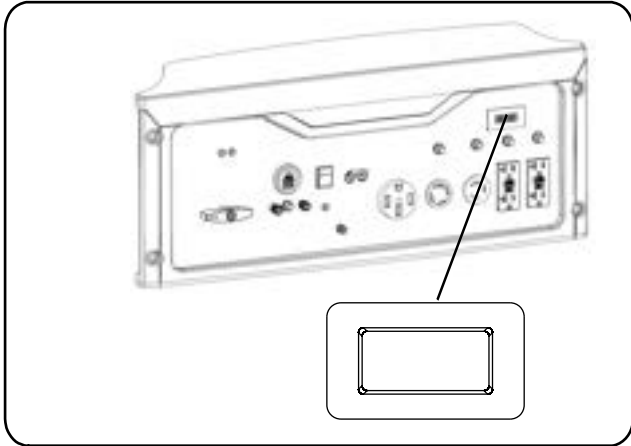

Fig 19

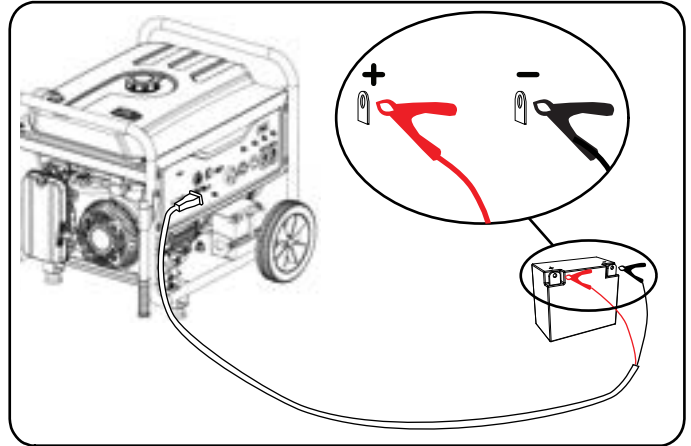

Fig 20

Cold Weather Operation

Under humid conditions where temperatures drop to 40°F (4°C) the carburetor and/or crankcase breather system may begin to freeze. To prevent cold weather performance issues, take the following steps:

1. Replace any old fuel with clean, fresh fuel.
2. Use SAE30 or SAE 10W-30 engine oil. Check oil daily or after every 8 hours of use.
3. Ensure generator is serviced according to the maintenance schedule under "Maintenance" section of the manual.
4. Shelter unit from elements.

MAINTENANCE

Regular maintenance will extend the life of this generator and improve its performance. The warranty does not cover items that result from operator negligence, misuse, or abuse. To receive full value from the warranty, operator must maintain the generator as instructed in this manual, including proper storage.



WARNING!

Before inspecting or servicing this machine, make sure the engine is off and no parts are moving. Disconnect the spark plug wire and move it away from the spark plug.

Pre-Operation Steps

Before starting the engine, perform the following pre-operation steps:

- Check the level of the engine oil and the fuel tank level.
- Make sure the air filter is clean.
- Remove any debris that has collected on the generator and around the muffler and controls. Use a vacuum cleaner to pick up loose debris. If dirt is caked on, use a soft bristle brush.
- Inspect the work area for hazards.

After Each Use

Follow the following procedure after each use:

- Close the Fuel Valve
- Turn the battery switch to stop
- Wait for the generator to become cool to the touch
- Store unit in a clean and dry area.

Maintenance Schedule

After First 5 Hours	Change Oil
After 8 Hours or Daily	Clean Debris from Generator and Air Filter area
	Check Engine Oil Level
Annually (25 hr Use)	Check and Clean Air Cleaner
	Change Engine Oil after the first 25 hours, again at 50 hours; then every 100 hours thereafter.
	Inspect Muffler and Spark Arrester
Annually (100 hr Use)	Service Spark Plug (Replace with NGK BP6ES, Champion N9YC or equivalent)
	Inspect Fuel Valve and Fuel Lines for leaks or damage
	Inspect Muffler and Spark Arrester
	Check and Clean Air Cleaner Assembly, Replace Air Filter
	Clean Cooling System Cylinder Head Fins and Flywheel Fan

MAINTENANCE

Changing Oil (See Fig 21)

- Run the Generator until the Engine is warm, then shut OFF.
- Place generator on a level surface.
- Remove the crankcase dipstick.
- Place an oil pan underneath the oil drain hole to collect used oil.
- Remove the oil drain plug and allow oil to drain completely.
- Reinstall oil drain plug, tighten securely.
- Carefully add SAE 30 or 10W-30 to empty reservoir until the oil reaches the threads of the oil fill hole (Crankcase Dipstick hole).
- Replace crankcase dipstick.

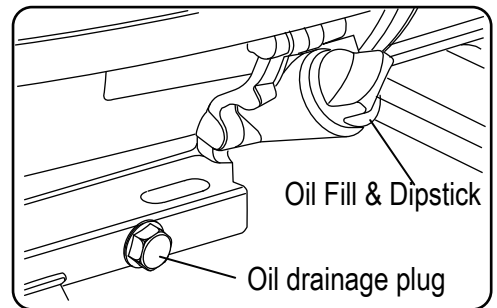
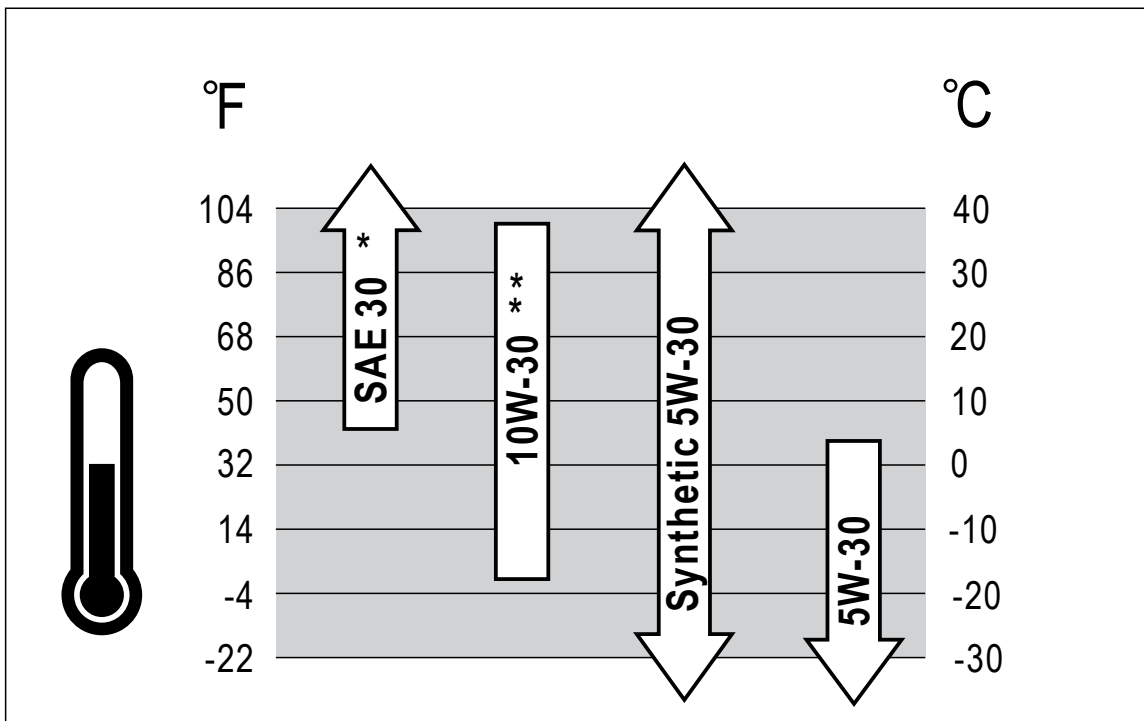

Fig 21

Oil Recommendations

- Do not use special additives.
- Outdoor temperatures can affect proper oil viscosity for the engine.
- Use the chart to select the best viscosity for the outdoor temperature range expected.



Note: * Below 40 °F (4 °C) the use of SAE 30 will result in hard starting.
** Above 80 °F (27 °C) the use of 10W-30 may cause increased oil consumption.
Check oil level more frequently.

MAINTENANCE



CAUTION!

Used oil should be disposed of at an approved disposal site. See your local oil retailer for more information.

Air Filter (See Fig 22)

A dirty air filter will reduce the life span of the engine, make it difficult to start the engine, and reduce the unit's performance.

- To clean, remove the air filter cover.
- Carefully pull the air filter out by lifting along the edges.
- Remove dirt from filter by tapping on it or having it blown out. Replace with new filter annually.
- Reinstall air filter so that it seals and replace air filter cover.

Checking Spark Plug (See Fig 23)

- Disconnect the spark plug wire from the spark plug.
- Before removing the spark plug, clean the area around its base to prevent debris from entering the engine.
- Clean carbon deposits off the electrode with a wire brush.
- Check the electrode gap and gently adjust gap to 0.70mm-0.80mm (.030-.031") if necessary.
- Reinstall spark plug and tighten to Torque 22–27 Nm (16-20 ft-lb).
- Reconnect spark plug wire.
- If spark plug is worn replace only with an equivalent replacement part. Spark plug should be replaced annually. (BOSCH F7TC, NGK BP6ES, CHAMPION N9YC or equivalent)

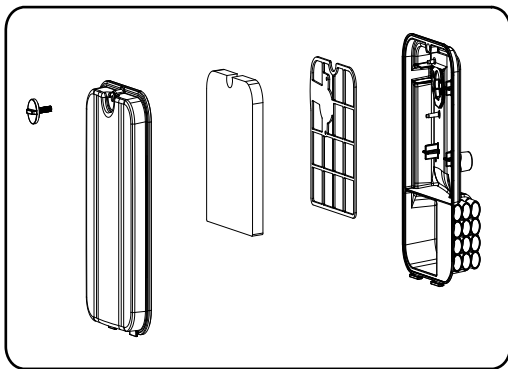

Fig 22

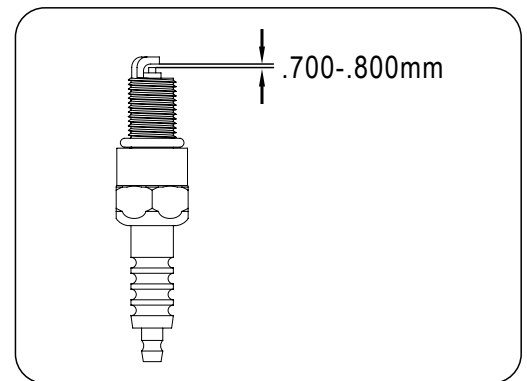

Fig 23

Spark Arrestor (See Fig 24)

- Inspect the spark arrestor for breaks or holes. Replace if necessary. To purchase a replacement spark arrestor contact PULSAR customer service.
- Use a brush to remove carbon deposits from the spark arrestor screen as needed.
- To remove the spark arrestor: While the muffler is cool, loosen the locking clamp and slide the spark arrestor out of the muffler. Reverse this process to install it.

Cooling System

Cooling system should only be serviced by an authorized dealer.

MAINTENANCE

High Altitude Operation

At high altitude, the standard carburetor air/fuel mixture will be too rich. Performance will decrease, and fuel consumption will increase. A very rich mixture will also foul the spark plug and cause hard starting. Operation at an altitude that differs from that at which this engine was certified, for extended periods of time, may increase emissions. High altitude performance can be improved by specific modifications to the carburetor. If you always operate your generator at altitudes above 5,000 feet (1,500 meters), have your dealer perform this carburetor modification. This engine, when operated at high altitude with the carburetor modifications for high altitude use, will meet each emission standard throughout its useful life. Even with carburetor modification, engine horsepower will decrease about 3.5% for each 1,000-foot (300-meter) increase in altitude. The effect of altitude on horsepower will be greater than this if no carburetor modification is made.



CAUTION!

Fuel tank must be empty before replacing fuel filter. Run unit until tank is empty, if needed, or inspect filter prior to fill-up.

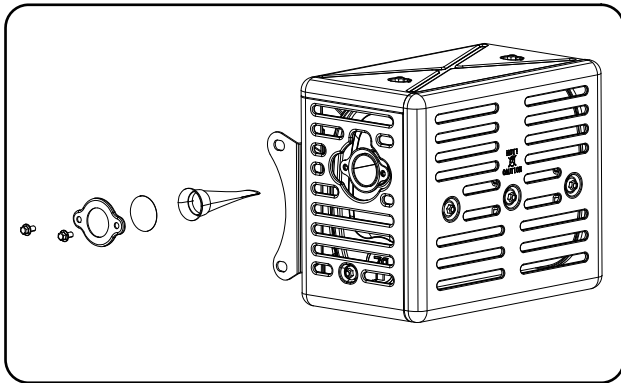

Fig 24

Draining Fuel Tank and Carburetor

To help prevent varnish deposits in the fuel system, drain the fuel from the tank and carburetor before storing the unit for long periods of time. This will help prevent starting problems in the future. If the unit is stored with fuel and the fuel becomes stale or turns gummy or to varnish the warranty does not cover the resulting repair or service.

Draining the fuel tank

- Turn the fuel valve to the OFF position.
- Turn the battery switch to stop.
- Remove the fuel line that leads from the carburetor to the petcock by squeezing the ends of the hose clamps and sliding the fuel line off.
- If needed, install a fuel hose that will extend to a suitable fuel container large enough to catch the fuel being drained from the tank.
- Turn the fuel valve to the ON position and open the fuel tank cap slightly to equalize pressure.
- When the fuel has drained from the tank, close the fuel valve and reinstall fuel line securely on petcock.

MAINTENANCE

Draining the carburetor

- Turn the fuel valve to the OFF position.
- Turn the battery switch to stop.
- Position a suitable container under the carburetor drain screw to catch fuel; loosen and remove the screw.
- Allow fuel to drain completely into container, be sure to wipe up any spilled fuel right away.
- Retighten drain screw, taking care that the gasket seal is in place.



CAUTION!

Consult your local hazardous waste management in your area for the proper way to dispose of used fuel.

Storage and Transportation of the Generator: (See Fig 26)

- Remove any debris that has collected on the generator and around the muffler and controls. Use a vacuum cleaner to pick up loose debris. If dirt is caked on, use a soft bristle brush.
- Inspect air cooling cylinder fins and flywheel fan. Remove any debris if obstructed.
- For short-term storage, start generator once every 7 days.
- For long-term storage, add fuel stabilizer to prevent stale fuel from causing varnish and gum deposits in the fuel system and carburetor.
- Store in a sheltered location and use a suitable cover to protect from dust.

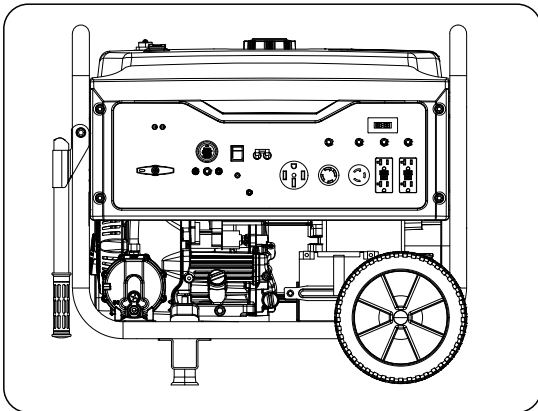

Fig 26

Engine Long Term Storage:

- Remove the spark plug and pour about 1 teaspoon of 10W30 Engine oil into the spark plug hole. Reinstall the spark plug. With the RUN/STOP switch in the STOP position pull the recoil starter cord several times to coat the cylinder walls with oil.
- Slowly pull the recoil starter until you feel the engine build compression (when you feel resistance). Leave the Engine in this state as this will prevent corrosion on the cylinder walls if stored for a long period of time.

TROUBLESHOOTING

Problem	Cause	Solution
Engine is running, but AC output is not available	<ol style="list-style-type: none"> 1. Open circuit breaker 2. Poor connection 3. Defective cord set 4. Connected device is faulty 5. Fault in generator 	<ol style="list-style-type: none"> 1. Reset circuit breaker 2. Check and repair 3. Check and repair 4. Connect a device that is working properly 5. Contact service department
Engine runs well without load but bogs down when loads are connected	<ol style="list-style-type: none"> 1. Short circuit in connected device 2. Generator is overloaded 3. Clogged fuel filter 4. Engine speed is too slow 5. Short circuit in generator 	<ol style="list-style-type: none"> 1. Disconnect device 2. See pg 17 "Don't overload generator" 3. Clean or replace fuel filter 4. Contact service department 5. Contact service department
Engine will not start, shuts down during operation, or starts and runs rough.	<ol style="list-style-type: none"> 1. RUN/STOP switch set to "STOP" 2. Dirty Air filter 3. Clogged fuel filter 4. Stale fuel 5. Spark plug wire disconnected from spark plug 6. Bad spark plug 7. Water in fuel 8. Fuel valve is in "OFF" position 9. Over choking 10. Low oil level 11. Rich fuel mixture 12. Intake valve stuck open or closed 13. Loss of engine compression 14. Engine has flooded 15. CO Sensor indicator light turn red 16. CO Sensor indicator light turn yellow 	<ol style="list-style-type: none"> 1. Turn switch to "RUN" 2. Replace Air filter 3. Clean or replace fuel filter 4. Replace fuel 5. Reconnect spark plug wire 6. Replace spark plug 7. Drain fuel tank and replace fuel 8. Turn fuel valve to "ON" position 9. Turn off choke 10. Fill crankcase to proper oil level & place generator on a level surface 11. Contact service department 12. Contact service department 13. Contact service department 14. Wait 5 minutes and crank engine 15. Move the generator to an open, outdoor area 16. Contact service department
Engine lacks power	<ol style="list-style-type: none"> 1. Generator is overloaded 2. Clogged fuel filter 3. Dirty Air filter 4. Engine needs servicing 	<ol style="list-style-type: none"> 1. See pg. 17 "Don't overload generator" 2. Clean or replace fuel filter 3. Replace Air filter 4. Contact service department
Engine "hunts" or falters	<ol style="list-style-type: none"> 1. Choke was opened too soon 2. Clogged fuel filter 3. Carburetor is running too rich or too lean 	<ol style="list-style-type: none"> 1. Move choke to middle position until engine runs smoothly 2. Clean or replace fuel filter 3. Contact service department

CO SENSOR

CO SENSOR

The CO Sensor monitors for the accumulation of poisonous carbon monoxide gas around the generator when the engine is running. If increasing levels of CO gas are detected, the CO Sensor automatically shuts down the engine.

The CO Sensor will also detect the accumulation of carbon monoxide from other fuel burning sources used in the area of operation. For example, if the exhaust of fuel burning tools is pointed at a CO Sensor-equipped generator, a shut-off may be initiated due to rising CO levels. This is not an error. Hazardous carbon monoxide has been detected. Move and redirect any additional fuel burning sources to dissipate carbon monoxide away from personnel and occupied buildings.

Note: Remote start-equipped generators must be restarted with the START/STOP button on the control panel after an automatic shut-down occurs.

Generators are intended to be used outdoors, far from occupied buildings and the exhaust pointed away from personnel and buildings. If misused and operated in a location that results in the accumulation of CO, like in a partially enclosed area, the CO Sensor shuts off the engine, notifies the user with a RED indicator light, and directs the user to read the Action Label for steps to take. The CO Sensor **DOES NOT** replace carbon monoxide alarms. Install battery-powered carbon monoxide alarm(s) in your home.

CO SENSOR INDICATOR LIGHTS

RED

Carbon monoxide accumulated around the generator. After shut-off, the RED indicator light in the CO Sensor area of the control panel will flash to provide notification that the generator was shut-off due to an accumulating CO hazard. The RED light will flash for at least five minutes after a CO shut-off.

Move the generator to an open, outdoor area far away from occupied spaces with exhaust pointed away. Once relocated to a safe area, the generator can be restarted. Introduce fresh air and ventilate the area where the generator had shut down.

YELLOW

A CO sensor system fault occurred. When a system fault occurs, the generator is automatically shut down and the YELLOW indicator light in the CO auto-shutoff area of the control panel will flash to provide notification that a fault has occurred. The YELLOW light will flash for at least five minutes after a fault. The generator can be re-started, but may continue to shutoff. A CO sensor fault can only be diagnosed and repaired by an authorized Pulsar service center.

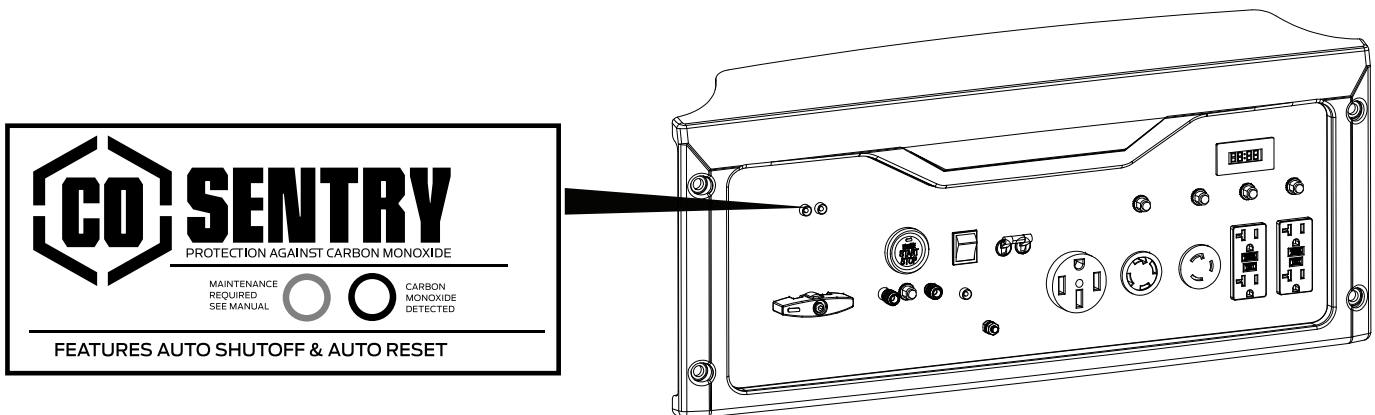

DIAGRAMS

