

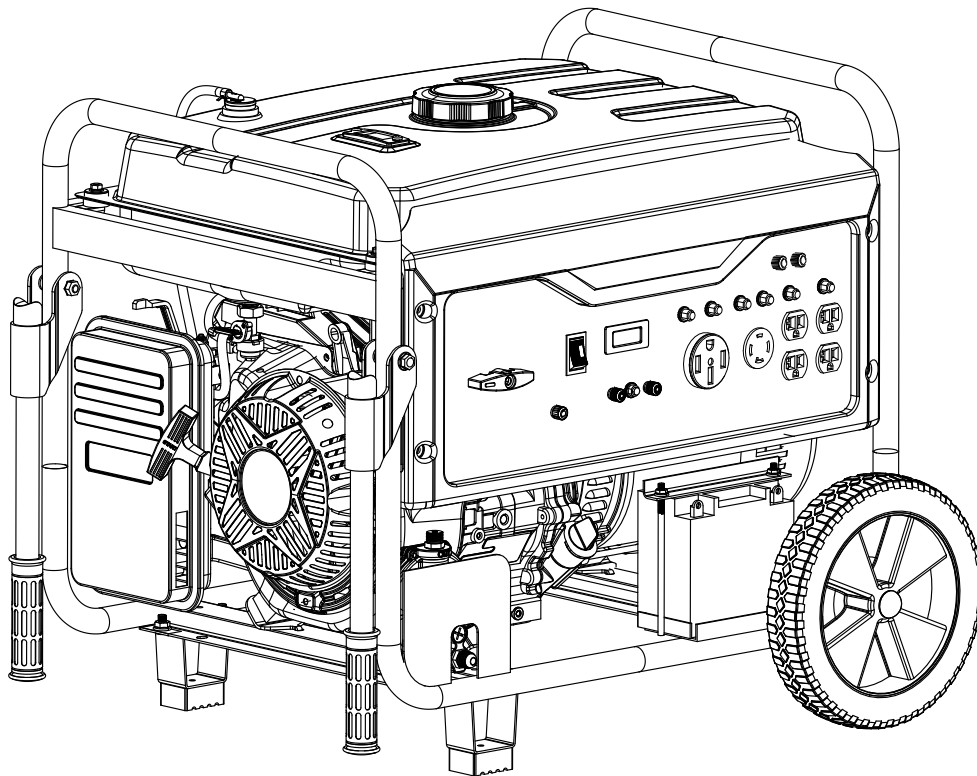

Model No. PG12000BCO

12000 Watt Dual-Fuel Open Frame Generator

# OPERATOR'S MANUAL



Warning: The Engine Exhaust from this product contains chemicals known to the State of California to cause cancer, birth defects or other reproductive harm.



**DO NOT RETURN TO STORE!**

**HAVE QUESTIONS OR NEED SERVICE?**



866-591-8921



support@pulsar-products.com

# Table of Contents

Safety Warnings . . . . .	1	Preparation . . . . .	11
Safety Instructions . . . . .	2	Battery . . . . .	11
CO Sentry . . . . .	4	Adding Engine Oil . . . . .	12
Names of Components . . . . .	6	Connecting a Propane Tank . . . . .	14
Control Panel . . . . .	7	Operation . . . . .	16
Specifications . . . . .	8	Maintenance . . . . .	20
Assembly . . . . .	9	Troubleshooting . . . . .	24

# Introduction

Thank you for choosing Pulsar Products!  
This manual provides instruction on how to operate and use your generator safely and correctly; be sure to read and understand this manual before using your generator. If you have ANY questions, please phone 866.591.8921 M-F or support@pulsar-products.com BEFORE using your generator.

All details and images in this Manual are believed to be accurate at the time of publication.

Pulsar Products reserves the right to make updates to this manual at any time.

Please contact Pulsar Support at 866.591.8921 or support@pulsar-products.com for the latest updates.

This manual is a permanent part of the generator set. If the generator is resold, kindly include this manual with the generator.

# Safety Warnings and Notices

## WARNING: Save This Manual For Future Reference

This manual contains important information regarding the safety, operation, maintenance, and storage of this product. Before use, read carefully and understand all cautions, warnings, instructions, and product labels. Failure to do so could result in serious personal injury and/or property damage.

## Safety Definitions

The words DANGER, WARNING, CAUTION, and NOTICE are used throughout this manual to highlight important information. Make sure that the meaning of this safety information is known to all who operate, perform maintenance on, or are near the generator.

 This safety alert symbol appears with most safety statements. It means to pay attention and be alert, your safety is involved! Please read and abide by the message that follows the safety alerts symbol.

### DANGER

DANGER indicates an imminently hazardous situation which, if not avoided, will result in death or serious injury.

### WARNING

WARNING indicates a potentially hazardous situation which, if not avoided, could result in death or serious injury.

### CAUTION

CAUTION indicates a potentially hazardous situation which, if not avoided, may result in minor or moderate injury. It may also be used to alert against unsafe practices.

### NOTICE











Failure to follow the instruction may result in the damage to your generator and other property.

## Safety Symbols

Follow all safety information contained in this manual and on the generator.

# Safety Instructions

Before operating your generator, you must read and understand the manual and familiarize yourself with the safe operation practices.

SYMBOL	DESCRIPTION
	Safety Alert Symbol
	Electrocution Hazard
	Asphyxiation Hazard
	Burn Hazard. DO NOT touch hot surfaces.
	Electrical Shock Hazard
	Fire Hazard
	Maintain Safe Distance
	Lifting Hazard
	Read Manufacturer's Instructions
	DO NOT Operate in Wet Conditions
	Ground. Consult with electrician to determine grounding requirements before

## Safety Precautions

### DANGER

Using a generator indoors **CAN KILL YOU IN MINUTES.** Generator exhaust contains carbon monoxide. This is a poison you cannot see or smell.



**NEVER** use inside a home or garage, **EVEN IF** doors and windows are open.



**ONLY** use **OUTSIDE** and far away from windows, doors, and vents.

### WARNING

**POISONOUS GAS HAZARD:** Engine exhaust contains carbon monoxide, a poisonous gas that could kill you in minutes. You **CAN NOT** smell it, see it, or taste it. Even if you do not smell exhaust fumes, you could still be exposed to carbon monoxide gas.

Operate this product **ONLY** outside far away from windows, doors, and vents to reduce the risk of carbon monoxide gas from accumulating and potentially being drawn towards occupied spaces.

Install battery-operated carbon monoxide alarms or plug-in carbon monoxide alarms with battery backup according to the manufacturer's instructions. Most smoke alarms cannot detect carbon monoxide gas.

**DO NOT** run this product inside homes, garages, basements, crawlspaces, sheds, or other partially enclosed spaces even if using fans or opening doors and windows for ventilation. Carbon monoxide can quickly build up in these spaces and can linger for hours, even after this product has shut off.

**ALWAYS** place this product downwind and point the engine exhaust away from occupied spaces. If you start to feel sick, dizzy, or weak while using this product, shut it off and get to fresh air **IMMEDIATELY** - then see a doctor; you may have carbon monoxide poisoning.

# Safety Instructions

## Correct Usage

Example location to reduce risk of carbon monoxide poisoning

- **ONLY** use outside and downwind, far away from windows, doors, and vents.
- Direct exhaust away from occupied spaces.



## Incorrect Usage

Do not operate in any of the following locations:

- Near any door, window, or vent
- Garage
- Basement
- Crawl Space
- Living Area
- Attic
- Entry Way
- Porch
- Mud Room

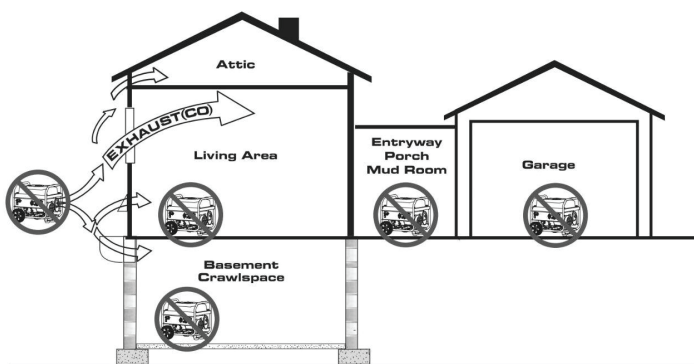

## WARNING

Starter cord kickback (rapid retraction) could pull hand and arm toward the engine faster than you can let go which could cause broken bones, fractures, bruises, sprains, or other serious injuries.

## WARNING



Fuel and its vapors are extremely flammable and explosive which could cause burns, fire, or explosion resulting in death or serious injury and/or property damage.

## When Adding Or Draining Gasoline

Turn the generator engine OFF and let it cool for at least 2 minutes before removing the fuel cap. Loosen the cap slowly to relieve pressure in the tank.

- Fill or drain fuel tank outdoors.
- DO NOT overfill the tank. Allow space for fuel expansion.
- If fuel spills, wipe it up and let the area dry before starting the engine.
- Keep fuel away from sparks, open flames, heat, and other ignition sources.
- Check fuel lines, tank, cap, and fittings frequently for cracks or leaks; replace if necessary.
- DO NOT light a cigarette or smoke anything.

## When Starting Equipment

- Ensure spark plug, muffler, fuel cap, and air cleaner are in place.
- DO NOT crank engine with spark plug removed.

## When Operating Equipment

- DO NOT operate this product inside any building, carport, porch, mobile enclosure, marine applications, or shed.
- DO NOT tip engine or equipment at an angle that causes fuel to spill.
- DO NOT stop the engine by moving the choke control to the "Start" position.
- DO NOT exceed the generator's wattage capacity.
- Start the generator and let the engine stabilize before connecting electrical loads.
- Connect electrical loads in the OFF position, then turn ON for operation.
- Turn electrical loads OFF and disconnect from the generator before stopping the generator.

# Safety Instructions

## NOTE

Improper treatment of the generator could damage it and shorten its life.

- Use generator only for intended applications.
- If you have questions about intended use, ask a dealer or contact your local Pulsar service center.
- Operate generator only on solid, level surfaces.
- DO NOT expose the generator to excessive moisture, dust, dirt, or corrosive vapors.
- DO NOT insert any objects through cooling slots.
- If connected devices overheat, turn them off and disconnect them from the generator.

Shut off the generator if:

- Electrical output is lost.
- Equipment sparks, smokes, or emits flames.
- Unit vibrates excessively.

## Parallel Kit Precautions



To prevent serious injury, death, and generator and/or equipment damage from electric shock and fire:

1. Follow Parallel Kit instructions provided with it for connection and use of a Parallel Kit.
2. Only connect two identical Inverter Generators together using a Parallel Kit.
3. Connect Parallel Kit only to terminals marked "Parallel" on the front of the Generator.
4. Do not remove or connect a Parallel Kit while the Generator is running.
5. Do not use a Parallel Kit that is attached to only one Generator.

## Carbon Monoxide Safety

### Carbon Monoxide

Generators are very convenient, but they can also be very dangerous. All fuel-burning appliances and equipment release a poisonous gas called carbon monoxide. Carbon monoxide (also known as CO) can be dangerous for humans and pets, even in small amounts, because it blocks oxygen from getting into your body. Carbon monoxide poisoning can lead to death in a very short time. It is odorless, tasteless and invisible, so you may be exposed without knowing it. That is why carbon monoxide is sometimes called "the silent killer."

## CO Sentry

The CO Sentry system was created to protect from dangerous carbon monoxide. Just like the detector for your home the CO Sentry tests the air for dangerous levels of carbon monoxide. If dangerous levels of carbon monoxide are detected this generator will automatically shut off.



Automatic shut off accompanied with a flashing RED light in the CO Sentry portion of the control panel is an indication that the generator was improperly located. If you start to feel sick, dizzy, weak, or carbon monoxide detectors in your home indicate an alarm, get to fresh air immediately. Call emergency services. You may have carbon monoxide poisoning.

## CO Sentry Indicator Lights

### RED

Carbon monoxide has accumulated around the generator. After shut off, the RED indicator light in the CO Sentry area of the control panel will flash to provide notification that the generator was shut off due to an accumulating CO hazard. The RED light will flash for at least five minutes after a CO shut off. Move the generator to an open, outdoor area far away from occupied spaces with exhaust pointed away. Once relocated to a safe area, the generator can be restarted. Introduce fresh air and ventilate the area where the generator had shut down.

### YELLOW

A CO Sentry system fault occurred. When a system fault occurs, the generator is automatically shut down and the YELLOW indicator light in the CO auto shut off area of the control panel will flash to provide notification that a fault has occurred. The YELLOW light will flash for at least five minutes after a fault. The generator can be re-started, but may continue to shut off.



# Components

Before operating your generator, you must read and understand the manual and familiarize yourself with the safe operation practices.

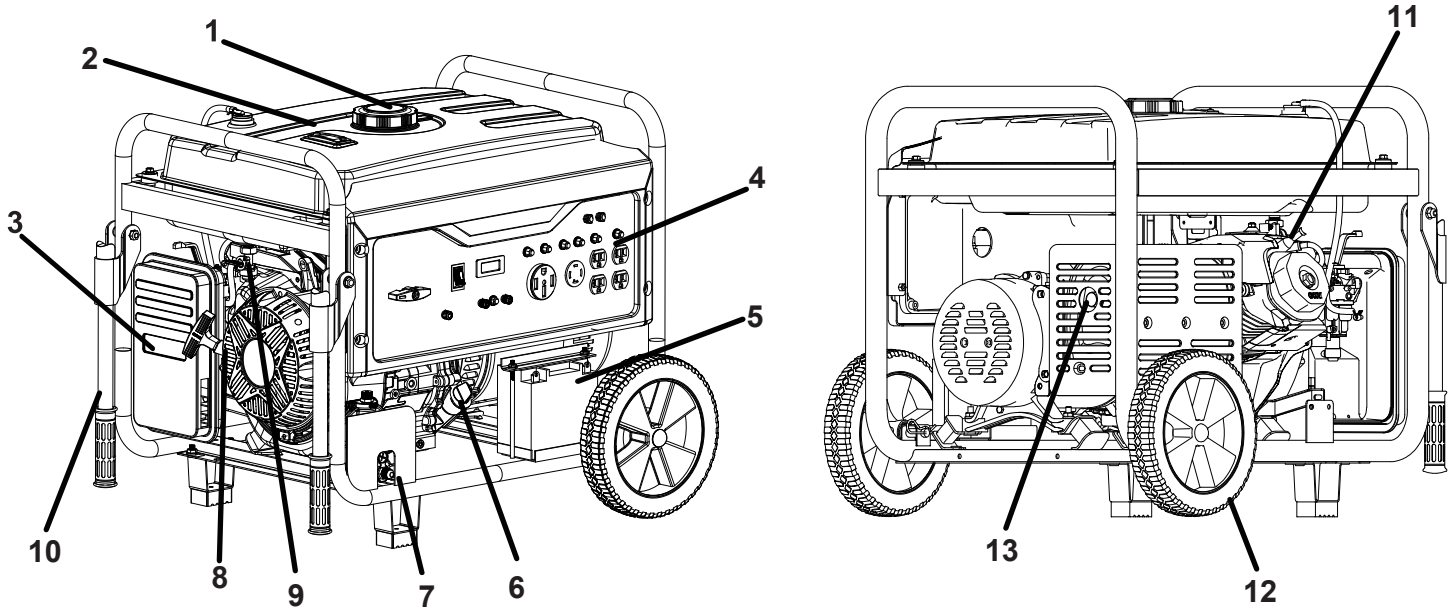

1. **Fuel Cap** : Add fuel here.
2. **Fuel gauge** : Used to observe fuel conditions.
3. **Air filter** : Clean or replace the air filter.
4. **Control Panel** : The control panel contains the outlets and operational controls.
5. **Battery** : Connect before start
6. **Oil dipstick** : Unscrew the oil dipstick to check oil levels and add oil when needed.
7. **LPG Supply Hose and Inlet Connector** : Gas connections must be secure, tight and comply with all local regulations.
8. **Recoil Handle** : Pull the recoil handle to manually start the engine.
9. **Carburetor** : If storing the generator for longer than six months, drain the fuel tank to prevent fuel separation, deterioration, and deposits in the fuel system.
10. **Carry Handles** : Helps transport the generator.
11. **Spark Plug Cover** : Spark plug can be maintained after removing this cover.
12. **Transport Wheels** : Helps transport the generator
13. **Muffler and Spark Arrestor** : The spark arrestor prevents sparks from exiting the muffler.



# Control Panel

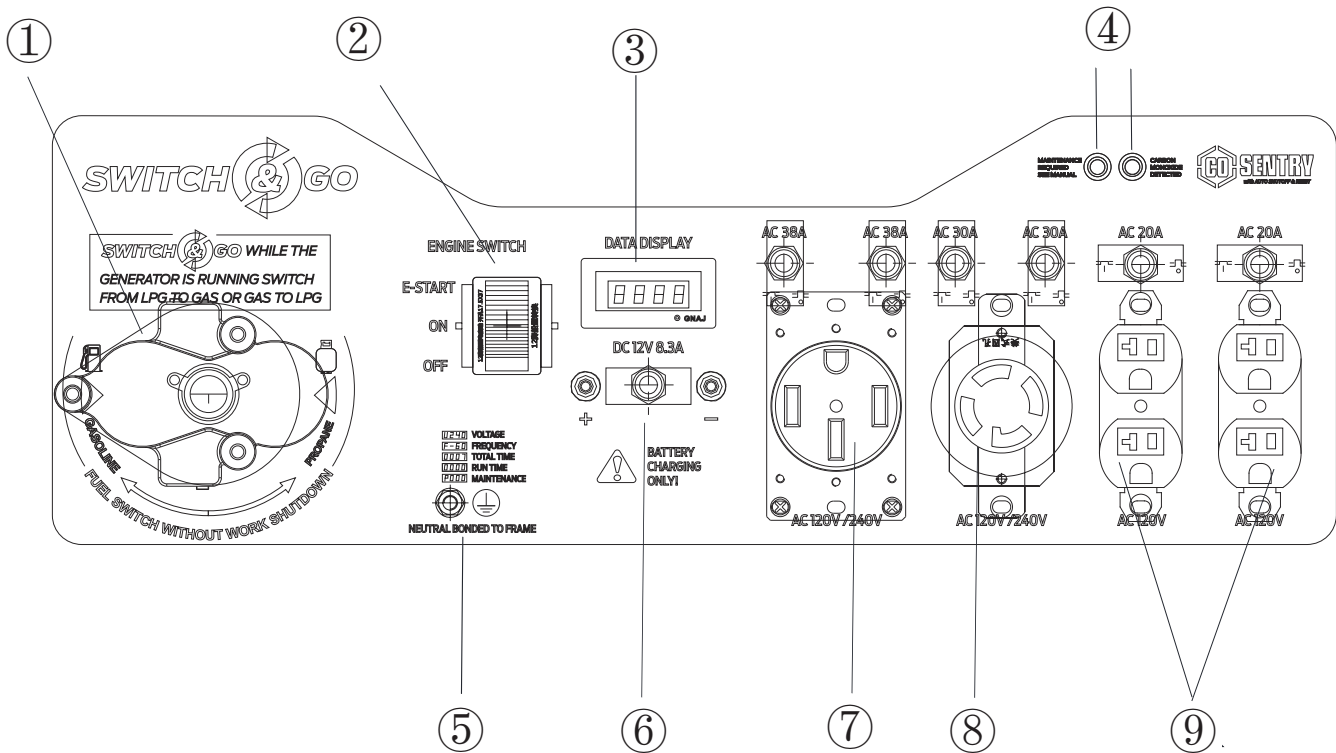

1. **Fuel Selector Switch:** Used to select Gasoline or Propane.
2. **Engine Off/On/start Switch**
3. **Data Display:** Push the mode button to cycle through the data display modes. (Voltage, Frequency (Hz), Lifetime Hours, Run Time, Maintenance Codes)
4. **CO Sentry Indicator Lights:** The CO Sentry monitors the accumulation of poisonous carbon monoxide gas. If increasing levels of CO gas are detected, the CO Sentry automatically shuts down the engine.
5. **Ground Terminal:** The ground terminal is used to externally ground the generator.
6. **DC 12 volt, 8.3 Amp binding posts**
7. **120/240 volt, 50 Amp, AC receptacle with Circuit Breaker.**
8. **120/240 volt, 30 Amp, AC receptacle with Circuit Breaker.**
9. **120 Volt, 20 Amp, AC Duplex Receptacle with Circuit Breaker.**

## Specifications

<b>Model</b>	<b>PG12000BCO</b>
<b>Engine Type</b>	<b>Single Cylinder, Four Stroke, Air Cooled Gasoline Engine</b>
<b>Displacement</b>	<b>457cc</b>
<b>Rated Power (kW) Gasoline</b>	<b>9.5</b>
<b>Peak Power (kW) Gasoline</b>	<b>12</b>
<b>Rated Power (kW) LPG/Propane</b>	<b>8.55</b>
<b>Peak Power (kW) LPG/Propane</b>	<b>10.8</b>
<b>Rated Voltage</b>	<b>120V/240V</b>
<b>Rated Frequency</b>	<b>60Hz</b>
<b>Phase</b>	<b>Single Phase</b>
<b>Starting Type</b>	<b>Recoil, Electric Start</b>
<b>Fuel Type</b>	<b>Regular Gasoline</b>
<b>Fuel Capacity</b>	<b>8 Gallons</b>
<b>Oil Type</b>	<b>10w-30</b>
<b>Oil Capacity</b>	<b>1.1L (37.2oz)</b>
<b>Maximum Ambient Temperature</b>	<b>104°F (40° C)</b>



# Assembly

## Preparation

Your generator requires some assembly. This generator ships from our factory without oil; it must be properly filled with oil before operation.

## Unpacking

1. Set the shipping carton on a solid, flat surface.
2. Remove everything from the carton except the generator.
3. First, assemble the wheels and carry handles. It is suggested to cut the panel of the carton to facilitate assembly (minimum two people cooperation is required). Please refer to page 10 for the wheel and carry handle assembly steps.
4. Using the carrying handles of the unit, carefully remove the generator from the box.

## Packing List

Check all loose parts to the following list. Contact your dealer if any loose parts are not included.

① 2 xWheels



② 2 xAxle



③ 2 xWasher



④ 2 xCotter pins



⑤ 2 xSupporting Feet



⑥ 6 xNuts (M8)



⑦ 2 xCarry Handles

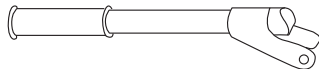

⑧ 2 xBolts (M8x50)



⑨ 4 xBushings (Flanged)



⑩ 1 xPropane connection hose

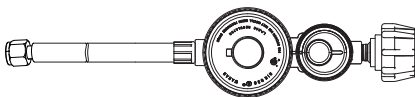

## Included Accessories

- Warranty Card
- Operator 's Manual
- Spark Plug Wrench
- Combination Wrench
- Funnel
- Measuring cup

# Assembly

## Wheel assembly (See Fig 1)

- Parts needed - ① 2×wheels, ②×2 axles, 2×washers, and ④ 2×hair pins.
- Raise or tilt generator so you can slide the wheel axle pin into the wheel, the washer, the wheel mounting hole located on the side of the frame.
- Secure the wheel assembly by inserting a hair pin through hole at the end of the wheel axle and pressing until it locks into place.
- Repeat this process to install the other wheel.

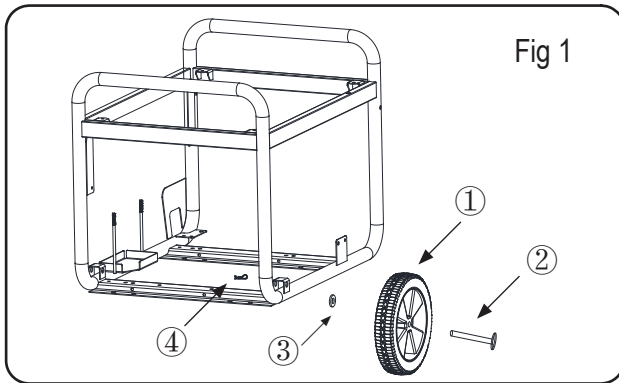

## Support Leg assembly (See Fig 2)

- Parts needed - ⑤ 2×Support Leg, ⑥ 4×Nuts (M8).
- Raise the front end of the generator high enough to gain access to the bottom of the frame. Securely position props underneath to support.
- Align the support legs with the holes in the generator frame and tighten the screws exposed by the support legs with nuts.
- Repeat this process to install the other support leg.

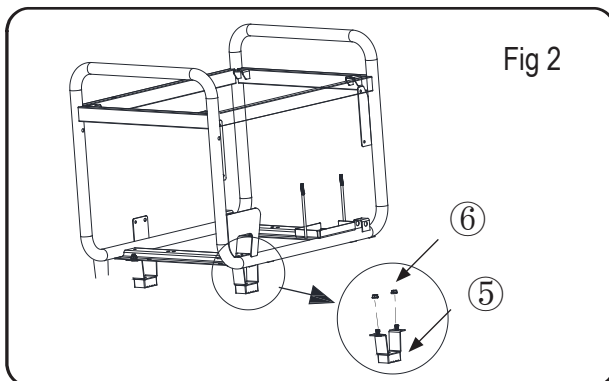

## Carry Handles assembly (See Fig 3)

- Parts needed - ⑥ 2×Nuts(M8), ⑦ 2×Carry handles, ⑧ 2×Bolts(M8x50), and ⑨ 4×Bushings (Flanged).
- Place 2 bushings on handle and slide handle in place with the pre-drilled hole on the generator frame.
- Insert bolt through the handle and frame and tighten with nut.
- Repeat this process to install the other carry handle.

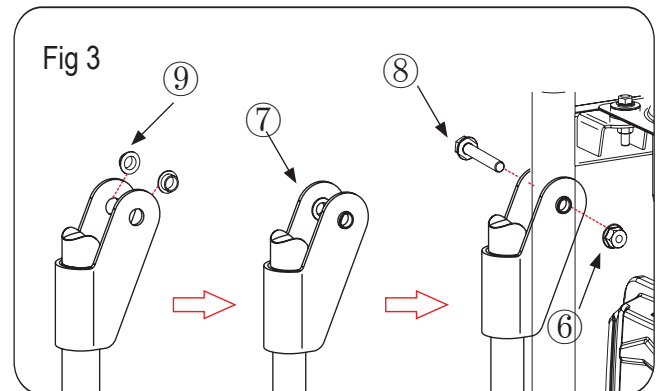

# Preparation

## Preparation

The generator battery is shipped disconnected for safety. You must connect the battery quick-connect cables before using the generator.

### Connecting the battery (See Fig 4)

- A quick connect battery plug is pre-installed on the battery and the generator, connect both together as shown.
- Never attempt to connect different colored battery wires together!

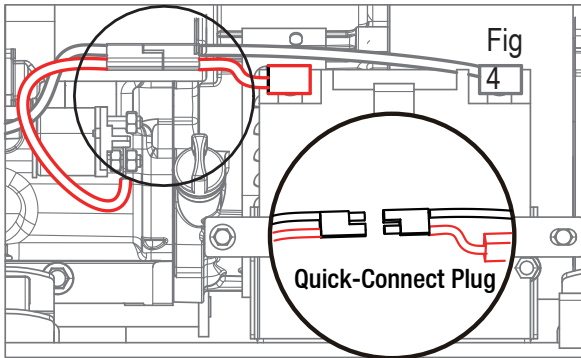

## NOTICE

### NOTE:

- When the engine is running, this generator will add charge back to the battery, much the same as an automobile does.
- Also, like an automobile, if the battery sits for several months, without use, the battery may need an external charge to start the generator electrically.

## CAUTION

Cover the terminals with the rubber covers When removing the battery for replacement: Remove the nut and bolt first from the negative (Black) post, then from the positive (Red) post, being careful not to short across the terminals. Always abide by the safety warnings provided with the battery. Remove the battery and dispose of it according to your local and state regulations.

## WARNING

### NON-SPILLABLE SEALED BATTERY

This is a ready filled, activated sealed battery. Never remove strip.

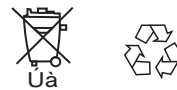

WEAR EYE PROTECTION, EXPLOSIVE GASES CAN CAUSE BLINDNESS OR INJURY.



DO NOT SMOKE OR SPARK NEAR THE BATTERY



SULFURIC ACID CAN CAUSE BLINDNESS OR SEVERE BURNS



IF ELECTROLYTE CONTACT THE SKIN WASH THE AREA IMMEDIATELY WITH CLEAN WATER

IF YOU GET ELECTROLYTE CONTACT WITH YOUR EYE, RINSE IMMEDIATELY WITH CLEAN WATER AND SEEK MEDICAL ATTENTION.

### Antidotes for battery acid

CONTACT	TREATMENT
External	Flush with water.
Internal	Drink large quantities of milk or water, followed by milk of magnesia, vegetable oil or beaten eggs. Get immediate medical attention.
Eyes	Flush with water. Get immediate medical attention.

# Preparation

## Preparation

Your generator requires some assembly. This generator ships from our factory without oil; it must be properly filled with oil before operation.

## Add Engine Oil

### **CAUTION**

DO NOT attempt to crank or start the engine before it has been properly filled with the recommended type and amount of oil. Damage to the generator from failing to follow these instructions will void your warranty.

### **NOTICE**

Failure to follow this instruction may result in the damage to your generator and other property.

If running the generator in extreme temperatures, refer to the following chart for recommended oil type.

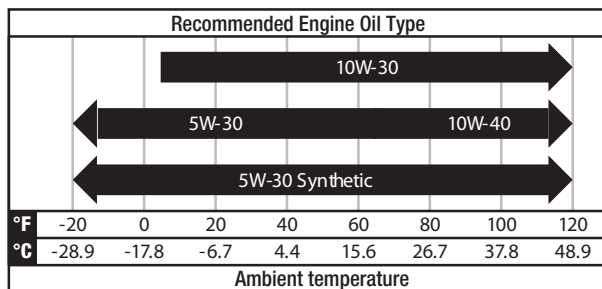

**NOTE:** Check engine oil level before each use, and add as needed.

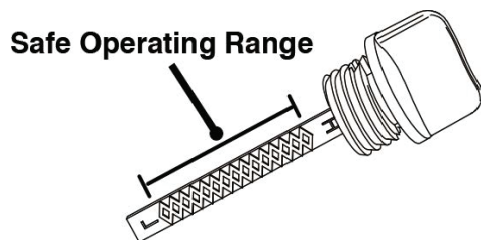

1. Place the generator on a solid, flat, level surface.
2. Remove oil fill cap/dipstick to add oil.
3. Using a funnel, add the appropriate type of oil until the oil level is at the proper level. SAE 10W-30 oil is recommended for general use. DO NOT OVERFILL. Replace oil fill cap/dipstick and secure cover.

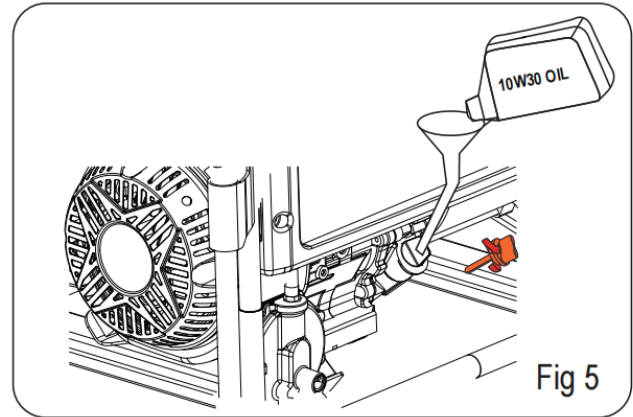

### **NOTICE**

Residual oil from the factory may remain in the engine, add oil slowly to prevent overfilling of the engine.

Once the oil has been added, oil level should appear 1-2 threads below the fill hole. DO NOT screw in the dipstick while checking.

## Preparation

### NOTICE

Check oil level often during the break-in period. Refer to the Maintenance section for recommended service intervals.

### CAUTION

This engine is equipped with a low oil shut-off and will stop when the oil level in the crankcase falls below a critical level.

### NOTICE

The first 5 hours of run time are the break-in period for the generator. During the break-in period stay at or below 50% of the running watt rating and vary the load occasionally to allow stator windings to heat and cool. Adjusting the load will also cause the engine speed to vary slightly and help seat the piston rings. After the 5-hour break-in period, change the oil.

### NOTICE

Synthetic oil may be used after the 5-hour initial break-in period. Using synthetic oil does not increase the recommended oil change interval. Full synthetic 5w-30 oil will aid in starting in cold < 41° F (5° C) temperatures.

### Add Gasoline( Fig. 6 )

### WARNING



TO PREVENT SERIOUS INJURY FROM FIRE:

Fill the gasoline tank in a well-ventilated area away from ignition sources. If the engine is hot from use, shut the engine off and wait for it to cool before adding gasoline. Do not smoke.

1. Set generator outdoors in a well-ventilated area, away from structures and people.
2. Slowly remove fuel cap.
3. Insert a funnel into the fuel tank and carefully pour gasoline into the tank until fuel level reaches 1 ½ inches below the top of the neck. Be careful not to overfill the tank to allow space for fuel expansion.

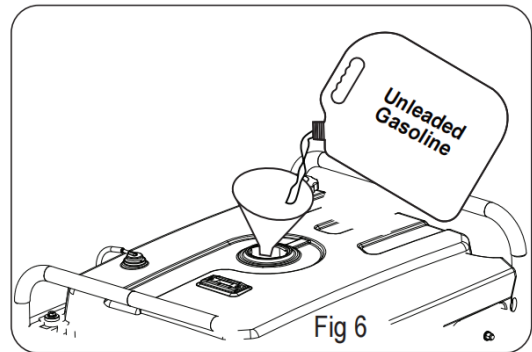

Fig 6

### DANGER

Do not overfill the gasoline the tank. Overfilling can result in a fire, explosion, or death.

### WARNING

Gasoline can expand. Do not fill the gasoline tank to the top. Leave a minimum of 1.5 inches open space. Gasoline fumes are explosive. Do not fill the tank near an open flame. Always check for gasoline spills.

- To ensure that the generator runs smoothly use only FRESH, FRESH GASOLINE WITH AN OCTANE RATING OF 87.
- Never use old gasoline.
- Avoid getting dirt or water in the gasoline tank.
- Gasoline WILL age in the tank and make it hard to start the generator in the future.
- Never store generator for extended periods of time with gasoline in the tank.

### Connecting a Propane Tank

### NOTICE

- Propane tanks that use liquid withdrawal system can not be used on these models.
- Confirm that the re-qualification date on the tank has not expired.
- DO NOT use included LPG hose for any other appliances.

# Preparation-Propane

## NOTICE

- All new propane tanks must be purged of air and moisture prior to filling. Used propane tanks that have not been plugged or kept closed must also be purged. The purging process should be done by a propane tank supplier (propane tanks from an exchange supplier should have been purged and filled properly).
- ALWAYS position the propane tank so the connection between the valve and the gas inlet will not cause sharp bends or kinks in the hose.

## ⚠ WARNING

Explosion hazard. DO NOT start generator if you smell propane. ALWAYS fully close the LPG tank valve and disconnect the propane hose from the generator when not in use. Never invert (turn up side down) a LPG tank while in use.

### Connecting a Propane Tank

1. Turn the generator OFF and leave on a flat surface in a well ventilated area.
2. Verify that the propane tank valve is in the fully closed position.

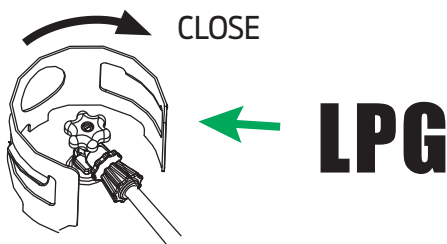

**IMPORTANT: DO NOT** use thread seal tape or any other type of sealant to seal the propane hose connection.

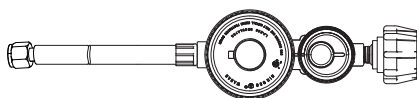

3. Remove the cover on the generator gas inlet.
4. Install the propane hose securely on the gas inlet (threaded tight) and check for a secure connection.
5. Remove the safety plug or cap from the propane tank valve and attach the other end of the hose to the LPG connector on the tank, hand-tighten. Then turn the fuel selector switch to "propane".
6. Turn the propane tank valve to the fully open position. Check all connections for leaks by wetting the fittings with a solution of soap and water. Bubbles which appear or bubbles which grow indicate that a leak exists. If a leak exists at a fitting, turn the propane tank valve to the fully closed position and tighten the fitting. Open the propane tank valve and recheck the fitting with the soap and water solution. If the leak continues or if the leak is not at a fitting then DO NOT use the generator and contact an authorized Pulsar service center.

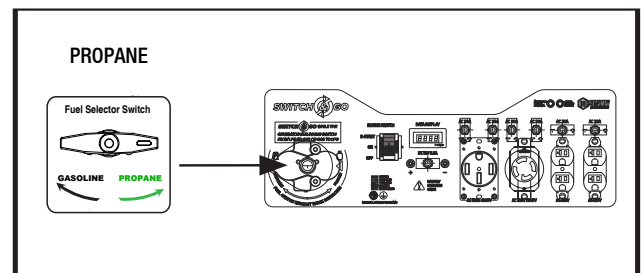
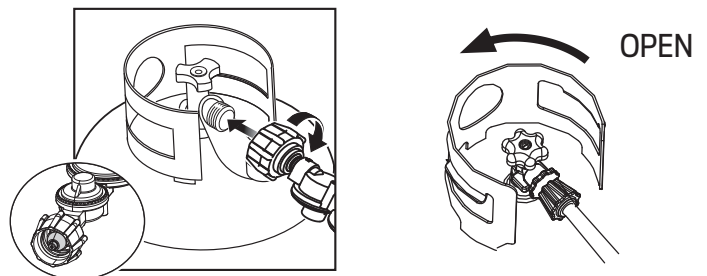

# Preparation

## Grounding The Generator

Attach grounding wire (if required by code)

- Ground the generator by connecting a suitable grounding cable to the grounding stud on the panel and tightening the nut.
- Connect the other end to a copper or brass grounding rod that's driven into the earth.

A generally acceptable grounding wire is a No. 12 AWG (American Wire Gauge) stranded copper wire.

Grounding codes vary by location. Please contact a local electrician to check the grounding regulations for your area.



Failure to properly ground the generator can result in electrocution.

## Connecting Generator to a Building Electrical System

If connecting generator to a building electrical system for standby power, you must use a qualified electrician to install a transfer switch. The power from the generator must be isolated from the utility power source. The connection must comply with all electrical codes and applicable laws.

Never handle the generator, electrical devices, or any cord while standing in water, while barefoot, or when hands or feet are wet.

Always keep the generator dry. Never store or operate generator in rain or under wet conditions.

Use a ground fault circuit interrupter (GFCI) in a damp or highly conductive area, such as metal decking or steel work.

Never plug electrical devices into generator having frayed, worn, or bare wires. Never touch bare wires or contact receptacles.

Never permit a child or unqualified person to operate generator. Always keep children a minimum of 10 feet away from the generator.

If using the generator for backup power, notify the utility company.

If connecting generator to a building's electrical system for standby power, you must use a qualified electrician to install a transfer switch. Failure to isolate the generator from the power utility could result in serious injury or death to electric utility workers.



# Operation

## Generator Location

### **! WARNING**

NEVER operate the generator inside any building, garage, basement, crawlspace, shed, or enclosure, including the generator compartment of a recreational vehicle.

NEVER operate or start the generator in the back of an SUV, camper, trailer, truck bed (regular sides, flat or other configuration), under staircases, stairwells, next to walls or buildings, or in any other location that will not allow for adequate cooling of the generator or for the proper exit of the exhaust flow.

DO NOT operate or store the generator in wet weather conditions such as rain or snow. Using a generator in wet conditions could result in serious injury or death due to electrocution.

Generators must have a minimum of 5 feet (1.5 m) of clearance from all combustible material.

Generators must also have a minimum of 5 feet (1.5 m) of airflow clearance on all sides to allow for adequate cooling, maintenance, and service.

Always place the generator in a well-ventilated area. NEVER place the generator near air intake vents or where exhaust fumes could be drawn into occupied or confined spaces.

Always carefully consider wind and air currents when positioning the generator.

Always allow generators to cool completely before transport or for storage purposes.

Failure to follow proper safety precautions may result in personal injury, damage to the generator, and void the manufacturer's warranty.

### **! WARNING**

During operation, the muffler and exhaust fumes will become hot. If there is inadequate cooling space or if the generator is blocked or enclosed, temperatures can rise quickly and may lead to a fire.

## Starting The Generator

Place generator on a level surface. All electrical loads **MUST** be disconnected from generator.

Check oil and fuel levels. If needed add oil, refill the LP gas cylinder, add gasoline.

Using the fuel selector switch, select GASOLINE or PROPANE.

Set the Switch & Go to your desired fuel and shut off the alternate fuel. (petcock for gasoline, tank valve for propane)

For propane, open the cylinder valve on the LP gas cylinder and turn off the flow of gasoline.

The fuel source can be switched while the engine is off or while it is running if a propane tank supply line is connected to the generator **BEFORE** operation.

If you switch from gasoline to another fuel source while the engine is running, it may run rough for a few seconds as it purges gasoline from the carburetor.

If the engine stops when switching fuel sources, disconnect all load then restart the unit on the fuel source of choice.

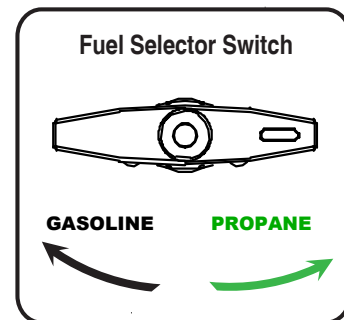

### **To switch to gasoline:**

Turn the fuel valve to the open position to start the flow of gasoline. Rotate the fuel selector switch to GASOLINE. Turn off the flow of propane gas.

### **To switch to propane:**

Open the cylinder valve on the LP gas cylinder to start the flow of propane. Rotate the fuel selector switch to PROPANE. Turn off the flow of gasoline.

# Operation

1. For Recoil Start: Firmly grasp and pull the recoil handle slowly until you feel resistance, let it retract then pull swiftly. If it fails to start successfully, wait for 3 seconds then repeat this step.

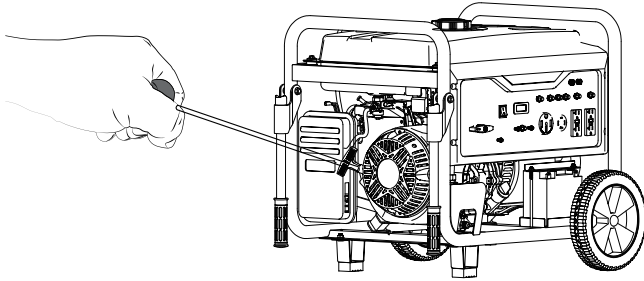

- When using gasoline turn fuel valve to the "ON" position.
- Move the fuel selector to "GAS" position.
- Slide the choke lever to the "Choke" position. SKIP THIS IF THE ENGINE IS WARM OR HOT.
- When using LPG move the fuel selector to "LPG" position.
- Slide the choke lever to the "Choke" position. SKIP THIS IF THE ENGINE IS WARM OR HOT.

## NOTICE

When the battery state of charge is below 10.5v:

- The electric start and the gasoline solenoid may not work.
- Switch to propane and use the recoil to start the engine.

2. For electric start: Push and hold the engine switch in the "START" position. Do not hold the START/ON/OFF switch in the "Start" position for more than 15 seconds. Allow 1 minute between starting attempts.

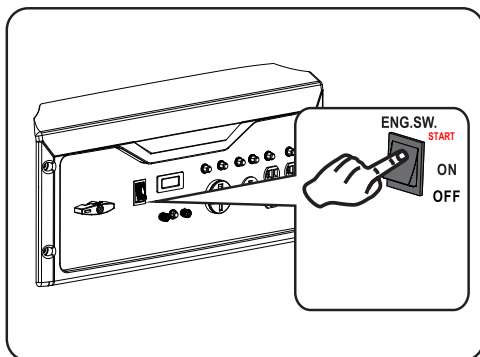

3. Plug in devices

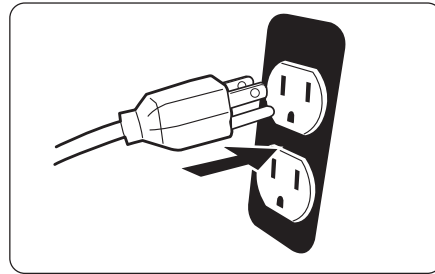

## ⚠ DANGER

Fire and explosion hazard. If the generator does not use propane, always place the propane tank valve in the full off position or disconnect the hose connection.

## NOTICE

When the engine is running, this generator will add charge back to the battery, much the same as an automobile does. Also, like an automobile, if the battery sits for several months, without use, the battery may need an external charge to start the generator electrically.

### Circuit breaker

1. The total combined load through the outlets on the generator shall not exceed the running power of the generator.
2. If a main circuit breaker activates, turn off the connected device, remove it from the port or outlet, and return the circuit breaker to on position.
3. Restart the engine and reconnect devices while being careful to not overload the generator.

### Low Oil Shut-Off

1. If the engine oil level is too low, the engine will automatically shut off.
2. The engine cannot be restarted until the proper amount of oil has been added.

# Operation

## Stop The Engine

1. Remove any connected loads from the control panel receptacles. Allow the generator to run at “no load” to reduce and stabilize engine and alternator temperatures.

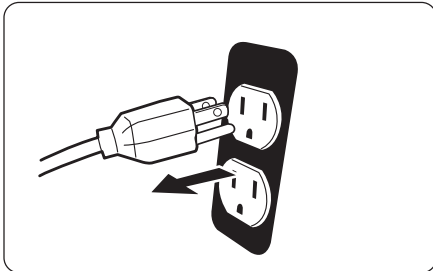

2. Move the engine START/ON/OFF switch to the “OFF” position.
3. Stop the flow of fuel.

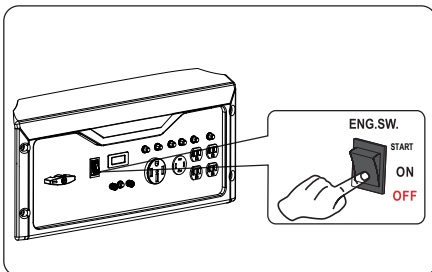

4. For gasoline, close the fuel valve.

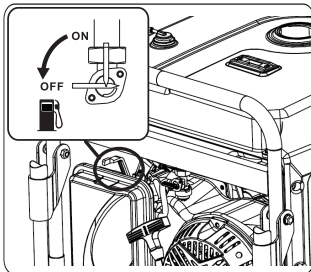

5. For propane, close the cylinder valve on the LP gas cylinder.
6. Disconnect the propane hose from the LP gas cylinder and the generator.

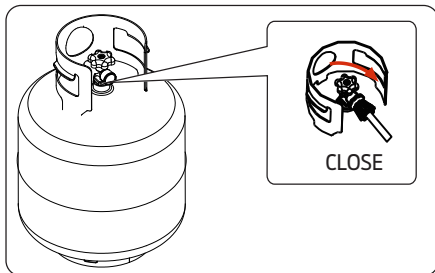

## Data Display

Push the mode button to cycle through the data display modes.

**Voltage:** Displays current voltage output.

**Frequency(Hz):** Displays power output frequency in Hertz.

**Lifetime Hours:** Displays the lifetime run hours.

**Run Time:** Displays current run time. Resets to zero when shut down.

Maintenance reminder displayed when required.

**Maintenance Codes:**

P25 - Change engine oil

P50 - Clean air filter, Change engine oil

P100 - Change engine oil, clean air filter, replace fuel filter.

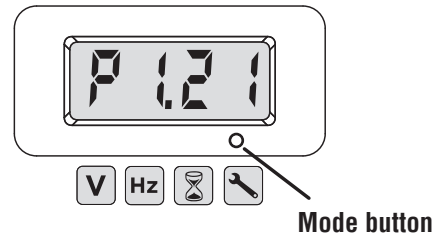

## BREAK-IN PERIOD

For proper break-in, do not exceed 50% of the rated running watts during the first five hours of operation.

Use supplied oil until first recommend oil change. Do not use full synthetic oil during break in period. Full synthetic oil may prevent proper break-in and seating of the piston rings.

Vary the load occasionally to allow stator windings to heat and cool and help seat the piston rings.

# Operation

## Generator Capacity

### NOTICE

Do not overload the generator's capacity. Exceeding your generator's wattage capacity can damage the generator and/or electrical devices connected to it.

Make sure the generator can supply enough continuous (running) and surge (starting) watts for the devices you will power at the same time.

The total power requirements (Volts x Amps=Watts) of all devices connected must be considered. Appliance and power tool manufacturers usually list rating information near the model or serial number. To determine power requirements:

1. Select the devices you will power at the same time.
2. Total the continuous (running) watts of these devices. This is the amount of power the generator must produce to keep the items running. See the wattage reference chart on the next page.
3. Estimate how many surge (starting) watts you will need. Surge wattage is the short burst of power needed to start electric motor-driven tools or appliances such as a circular saw or refrigerator. Not all motors start at the same time, total surge watts can be estimated by adding only the item(s) with the highest additional surge watts to the total rated watts from step 2.

Example:

Tool or Appliance	Running Watts*	Starting Watts*
RV Air Conditioner (13,000 BTU)	1100	1800
TV (Flat Screen)	150	150
RV Refrigerator	180	600
Radio	50	50
Light (75 Watts)	75	75
Coffee Maker	600	600
	2155 Total	3275
	Running Watts*	Highest Starting Watts*

\*Wattages listed are approximate. Verify actual wattage.

## High Altitude Operation

At high altitude, the standard carburetor air/fuel mixture will be too rich. Performance will decrease, and fuel consumption will increase. A very rich mixture will also foul the spark plug and cause hard starting. Operation at an altitude that differs from that at which this engine was certified, for extended periods of time, may increase emissions. High altitude performance can be improved by specific modifications to the carburetor. If you always operate your generator at altitudes above 5,000 feet (1,500 meters), have your qualified technician perform this carburetor modification. This engine, when operated at high altitude with the carburetor modifications for high altitude use, will again meet each emission standard. Even with carburetor modification, engine power will decrease about 3.5% for each 1,000-foot (300-meter) increase in altitude.

# Maintenance

## WARNING

Turn the generator “OFF”, wait for the engine to cool, and disconnect the spark plug cable before performing any inspection, maintenance, or cleaning procedures.

**EQUIPMENT FAILURE:** Do not use damaged equipment. If abnormal noise, vibration, or excess smoking occurs, have the problem corrected before further use.

Many maintenance procedures, including any not detailed in this manual, will need to be performed by a qualified technician for safety. If you have any doubts about your ability to safely service the equipment or engine, have a qualified technician service the equipment instead.

## Power

### Cleaning, Maintenance, and Lubrication Schedule

Note: This maintenance schedule is intended as a general guide. If performance decreases or if equipment operates unusually, have the generator inspected at once. The maintenance needs of generator will differ depending on factors such as duty-cycle, temperature, air quality, fuel quality.

Note: The following procedures are in addition to the regular checks and maintenance explained as part of the regular generator.

Procedure	Before Each Use	Monthly or every 8 hr. of use	Every 3 mo. or 50 hr. of use	Every 6 mo. or 100 hr. of use	Yearly or every 300 hr. of use	Every 2 Years
1. Brush off outside of engine 2. Check engine oil level 3. Check air filter	✓					
Change engine oil				✓		
Clean/replace air cleaner			✓			
1. Check and clean spark plug 2. Check and clean spark arrestor				✓		
1. Check/adjust idle speed 2. Check/adjust valve clearance 3. Clean fuel tank, strainer and carburetor 4. Clean carbon build-up from combustion chamber					✓	
Replace fuel line if necessary						✓

# Maintenance

## Checking and Filling Fuel

### **! WARNING**

TO PREVENT SERIOUS INJURY FROM FIRE: You must shut off the engine and allow it to cool before refueling.

1. Clean the Fuel Cap and the area around it.
2. Unscrew and remove the Fuel Cap.
3. Remove the strainer and discard any dirt and debris, then replace the strainer.

Note: Do not use gasoline containing more than 10% ethanol (E10). Do not use E85 ethanol. Add a fuel stabilizer ( such as Sta-Bi or Pri-G ) to the gasoline or the Warranty is VOID.

Note: Do not use gasoline that has been stored in a metal fuel container or a dirty fuel container. It can cause particles to enter the carburetor, affecting engine performance and/or causing damage.

4. Add fuel, if needed.
5. Replace the Fuel Cap.
6. Wipe up any spilled fuel and allow excess to evaporate before starting the engine. To prevent FIRE, do not start the engine while the smell of fuel hangs in the air.

## Engine Oil Change

### **! CAUTION**

Oil is very hot during operation and can cause burns. Wait for the engine to cool before changing the oil.

1. Turn the generator off and allow the engine to cool for 30 minutes.
2. Place the generator on a level surface in a well-ventilated area.

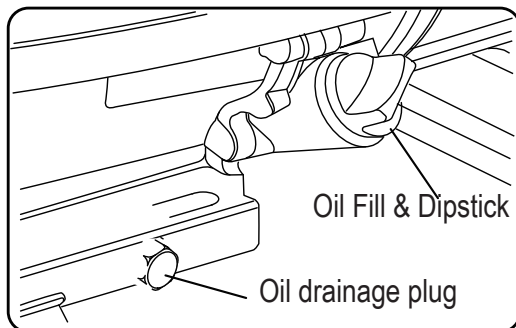

3. Place an oil drain pan under the generator and center it under the oil drain opening.
4. Remove the oil drain plug from the generator, tilt the generator slightly to facilitate drainage, and wait for the oil to drain completely. Recycle used oil.
5. Clean the top of the oil fill and the area around it.
6. Add the appropriate type of oil until the oil level is at the proper level. SAE 10w-30 oil is recommended for general use. Note: Make sure the generator is level when adding oil to prevent overfilling which could cause engine damage.
7. Check engine oil level daily and add as needed. Remove and clean the dipstick. Reinsert the dipstick but do not screw it back in. Remove the dipstick and verify the oil is at the correct level.
8. When the engine oil is at the correct level, reinstall the dipstick and screw it down until it is sealed. then, reinstall the right-side panel.

### Safe Operating Range

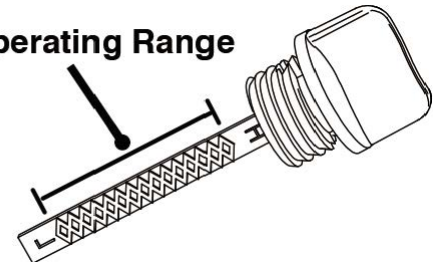

### NOTICE

- Do not attempt to run the generator with too little oil. The engine will not start with low or no engine oil.
- Change the oil while the engine is warm but not hot. Warm engine oil drains more quickly and thoroughly than cool oil. Contact with hot oil will cause serious burns

# Maintenance

## Air Filter Maintenance

1. To clean, Remove Air Filter Cover- see figure below.

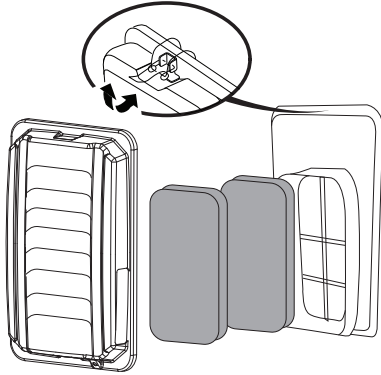

2. Remove the air filter element.
3. Wash the foam air filter element in hot, soapy water, squeezing the solution through the foam until it is clean, rinse the air filter element with clear water and dry it thoroughly before reinstallation.

**NOTE:** Avoid contact with engine oil. Wear protective clothing and safety glasses. Wash all exposed skin with soap and water.

## Spark Arrestor Maintenance

### **⚠ WARNING**

TO PREVENT SERIOUS INJURY AND FIRE:  
Operate only with proper spark arrestor installed

### **⚠ WARNING**

The operation of this protective clothing and gloves may create sparks that can start fires around dry vegetation. A spark arrestor may be required. The operator should contact local fire agencies for laws or regulations relating to fire prevention requirements.

1. Inspect the spark arrestor for breaks or holes. Replace if necessary. To purchase a replacement spark arrestor contact PULSAR customer service.
2. Use a brush to remove carbon deposits from the spark arrestor screen as needed.
3. To remove the spark arrestor: While the muffler is cool, loosen the locking clamp and slide the spark arrestor out of the muffler. Reverse this process to install it.

### **⚠ WARNING**

TO PREVENT ACCIDENTAL BRUSH FIRE, secure spark arrestor back in place immediately after cleaning and before further operation.

## Spark Plug Maintenance

1. Disconnect the spark plug wire from the spark plug.

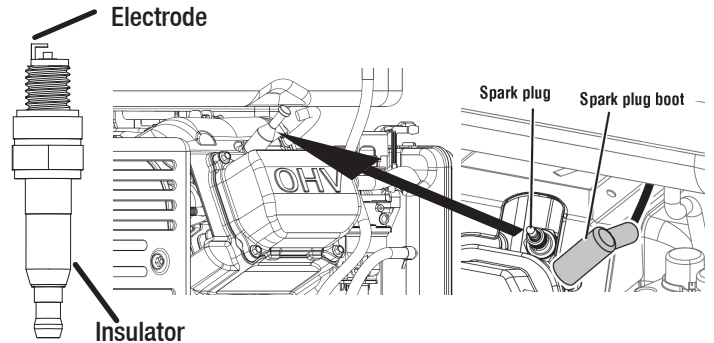

2. Use an air compressor (or vacuum cleaner), blow out any debris from around the spark plug, then carefully remove the spark plug boot from the plug.
3. Using the Spark Plug Wrench, unscrew and remove the Spark Plug.
4. Inspect the Spark Plug: If the electrode is oily, clean it using a clean, dry rag. If the electrode has deposits on it, clean it with a brass wire brush. If the white insulator is cracked or chipped, replace the spark plug.
5. Inspect and adjust the spark plug gap. (see below, Note special tools are required.)
6. If spark plug is worn replace only with an equivalent replacement part. Spark plug should be replaced annually.

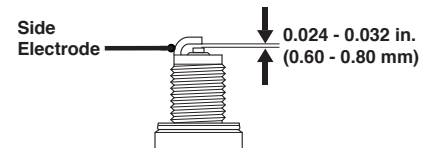

**Spark plug gap:** 0.024 – 0.032 in. (0.60 – 0.80 mm)



# Maintenance

## NOTICE

Use only BPR6ES (NGK) type spark plug or equivalent. Using an incorrect spark plug may damage the engine.

- When installing a new spark plug, adjust the electrode gap to the specification on the Specifications Chart. Do not pry against the center electrode, the spark plug can be damaged.
- Apply anti-seize material to Spark Plug threads. Install the new spark plug or the cleaned spark plug into the engine.

- Hand-tighten until the gasket contacts the cylinder head, then tighten about 3/4 turn more.

## NOTICE

Tighten the Spark Plug properly. If loose, the Spark Plug will cause the engine to overheat. If overtightened, the threads in the engine block will get damaged.

- Re-install the Spark Plug Access Cover.

## Storage

When the generator is to remain idle for longer than 20 days, prepare the engine for storage as follows:

### 1. CLEANING:

Wait for the engine to cool, open both side access panels and blow (or vacuum) any dirt or debris.

## NOTICE

Do not clean using water. The water will gradually enter the engine and cause damage.

### 2. FUEL:

#### Gasoline Treatment/Draining the Fuel Tank

To protect the fuel tank during storage, fill the tank with fresh gasoline that has been treated with a fuel stabilizer additive (such as Sta-Bil, or Pri-G).

Follow fuel stabilizer manufacturer's recommendations for use.

## WARNING

Fill the fuel tank in a well-ventilated area away from ignition sources. If the engine is hot from use and wait for it to cool before adding fuel. Do not smoke or vape anything.

## Draining the Carburetor

Shut off gasoline flow by moving the fuel petcock under the tank, place an appropriate container under the carburetor and carefully remove the drain bolt from the bottom of the carburetor bowl, allowing the fuel to drain completely. Replace the drain bolt after draining.

Aged gasoline that has not been treated with stabilizer ahead of time must be safely drained and disposed of, never run old gasoline through the engine.

## WARNING

To prevent serious injury and fire, move the fuel petcock under the tank to shut off gasoline supply before draining the carburetor.

### 3. Extended storage:

- Change engine oil.
- Clean out the area around the spark plug. Remove the spark plug and pour one tablespoon of engine oil into the cylinder through the spark plug hole.
- Replace spark plug, but leave spark plug boot.
- Pull Recoil to distribute oil in the cylinder. Stop after one or two revolutions when you feel the piston start the compression stroke (when you start to feel resistance).

### 4. STORAGE AREA:

Cover and store in a dry, level, well-ventilated area out of reach of children. The storage area should also be away from ignition sources, such as water heaters, clothes dryers, and furnaces.

## NOTICE

During extended storage periods, the engine should be started every 3 months and allowed to run for 15-20 minutes.

### 5. AFTER STORAGE:

Untreated gasoline will deteriorate quickly. Drain the fuel tank and change to fresh fuel if untreated gasoline has been sitting for a month, if treated gasoline has been stored beyond the fuel stabilizer's recommended time, or if the engine does not start.

# Troubleshooting

Problem	Cause	Solution
Engine is running, but AC output is not available	<ol style="list-style-type: none"> <li>1. Open circuit breaker</li> <li>2. Poor connection</li> <li>3. Defective cord set</li> <li>4. Connected device is faulty</li> <li>5. Fault in generator</li> </ol>	<ol style="list-style-type: none"> <li>1. Reset circuit breaker</li> <li>2. Check and repair</li> <li>3. Check and repair</li> <li>4. Connect a device that is working properly</li> <li>5. Contact service department</li> </ol>
Engine runs well without load but bogs down when loads are connected	<ol style="list-style-type: none"> <li>1. Short circuit in connected device</li> <li>2. Generator is overloaded</li> <li>3. Clogged fuel filter</li> <li>4. Engine speed is too slow</li> <li>5. Short circuit in generator</li> </ol>	<ol style="list-style-type: none"> <li>1. Disconnect device</li> <li>2. See pg 17 "Don't overload generator"</li> <li>3. Clean or replace fuel filter</li> <li>4. Contact service department</li> <li>5. Contact service department</li> </ol>
Engine will not start, shuts down during operation, or starts and runs rough.	<ol style="list-style-type: none"> <li>1. RUN/STOP switch set to "STOP"</li> <li>2. Dirty Air filter</li> <li>3. Clogged fuel filter</li> <li>4. Stale fuel</li> <li>5. Spark plug wire disconnected from spark plug</li> <li>6. Bad spark plug</li> <li>7. Water in fuel</li> <li>8. Fuel valve is in "OFF" position</li> <li>9. Over choking</li> <li>10. Low oil level</li> <li>11. Rich fuel mixture</li> <li>12. Intake valve stuck open or closed</li> <li>13. Loss of engine compression</li> <li>14. Engine has flooded</li> <li>15. CO Sensor indicator light turn red</li> <li>16. CO Sensor indicator light turn yellow</li> </ol>	<ol style="list-style-type: none"> <li>1. Turn switch to "RUN"</li> <li>2. Replace Air filter</li> <li>3. Clean or replace fuel filter</li> <li>4. Replace fuel</li> <li>5. Reconnect spark plug wire</li> <li>6. Replace spark plug</li> <li>7. Drain fuel tank and replace fuel</li> <li>8. Turn fuel valve to "ON" position</li> <li>9. Turn off choke</li> <li>10. Fill crankcase to proper oil level &amp; place generator on a level surface</li> <li>11. Contact service department</li> <li>12. Contact service department</li> <li>13. Contact service department</li> <li>14. Wait 5 minutes and crank engine</li> <li>15. Move the generator to an open, outdoor area</li> <li>16. Contact service department</li> </ol>
Engine lacks power	<ol style="list-style-type: none"> <li>1. Generator is overloaded</li> <li>2. Clogged fuel filter</li> <li>3. Dirty Air filter</li> <li>4. Engine needs servicing</li> </ol>	<ol style="list-style-type: none"> <li>1. See pg. 17 "Don't overload generator"</li> <li>2. Clean or replace fuel filter</li> <li>3. Replace Air filter</li> <li>4. Contact service department</li> </ol>
Engine "hunts" or falters	<ol style="list-style-type: none"> <li>1. Choke was opened too soon</li> <li>2. Clogged fuel filter</li> <li>3. Carburetor is running too rich or too lean</li> </ol>	<ol style="list-style-type: none"> <li>1. Move choke to middle position until engine runs smoothly</li> <li>2. Clean or replace fuel filter</li> <li>3. Contact service department</li> </ol>

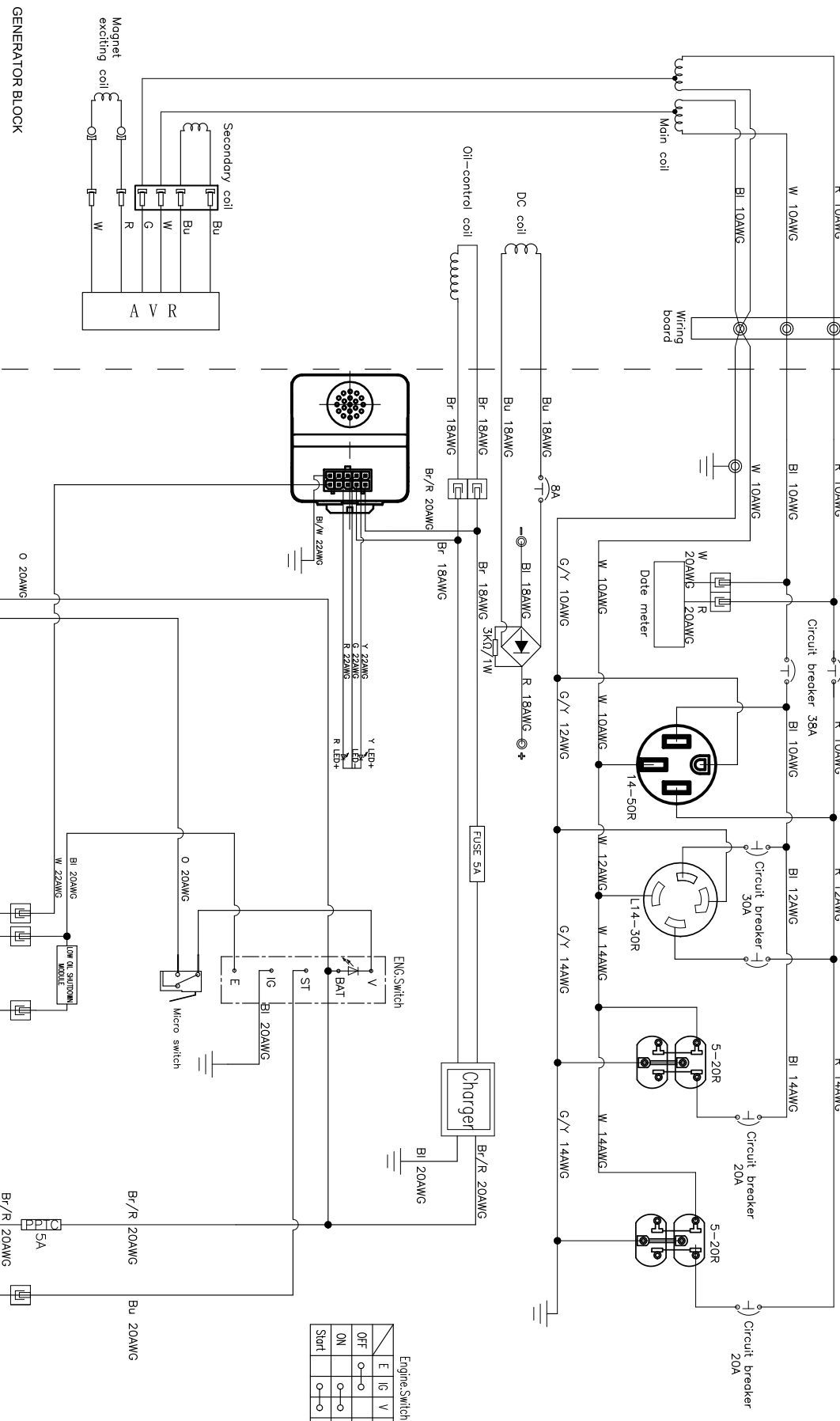

Engine-Switch

	E	IG	V	BAT	ST
OFF	○	○	○	○	○
ON	○	○	○	○	○
Start	○	○	○	○	○

Bl	Black	Br	Brown	G/Y	Green/Yellow
R	Red	Br/R	Brown/red	Y	Yellow
Bu	Blue	G	Grey	O	Orange
W	White	B/W	Black/White	G	Green

GENERATOR BLOCK

ENGINE BLOCK

Model 1: DGLG11050E	Model 1 Revision Level: 01
Doc No.: 716149	Doc Revision Level: 01
Title: SCHEMATIC	Ed. Date: 06/11/24